

# Structural Concrete Design using Strut-and-Tie Methodology

September 19<sup>th</sup>, 2019

4 PDHs

Presented By:

Jerry Pfuntner, P.E., S.E., P.Eng.



# Presenter Introduction

- Technical Director for the FINLEY Engineering Group, Inc.
- Adjunct Lecturer – University of Florida
  - Design of Highway Bridges
  - Advanced Bridge Design
- Over 25 years Bridge Design Experience



# Agenda

- Introduction
- Strut-and-Tie design philosophy
- Model Development
- Reinforcement Detailing
- Post-tensioning Detailing
- Use of FEA modelling to develop complex strut-and-tie models

# Slide Formating

- Seminar will be based on both the ACI and AASHTO Codes
- All loads will be assumed factored as per ACI or AASHTO
- ACI – Left side of Slide

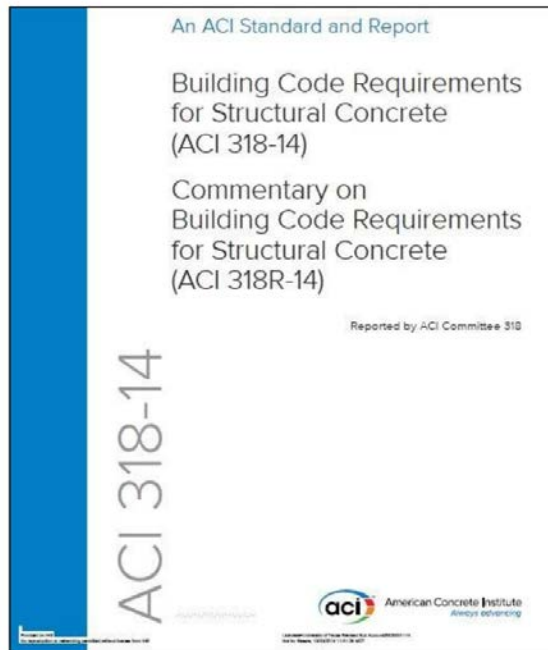

- AASHTO – Right side of Slide

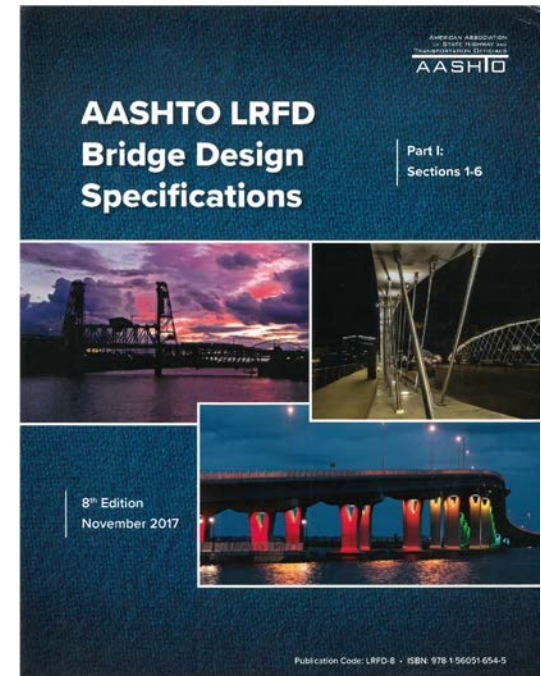

# References

- Schlaich, Jörg, Kurt Schäfer, and Mattias Jennewein. “Toward a Consistent Design of Structural Concrete.” *PCI Journal* 32.3 (1987): 75-150
- FHWA NHI Course – Strut-and-Tie Modelling (STM) for concrete structures, October 2017

# Bernoulli's Hypothesis

- Bernoulli's Hypothesis states:
  - “Plane Sections remain plane after bending..”
- A linear distribution of strain is the basis for flexural design of reinforced concrete to include ultimate capacity

# Strut-and-Tie Model

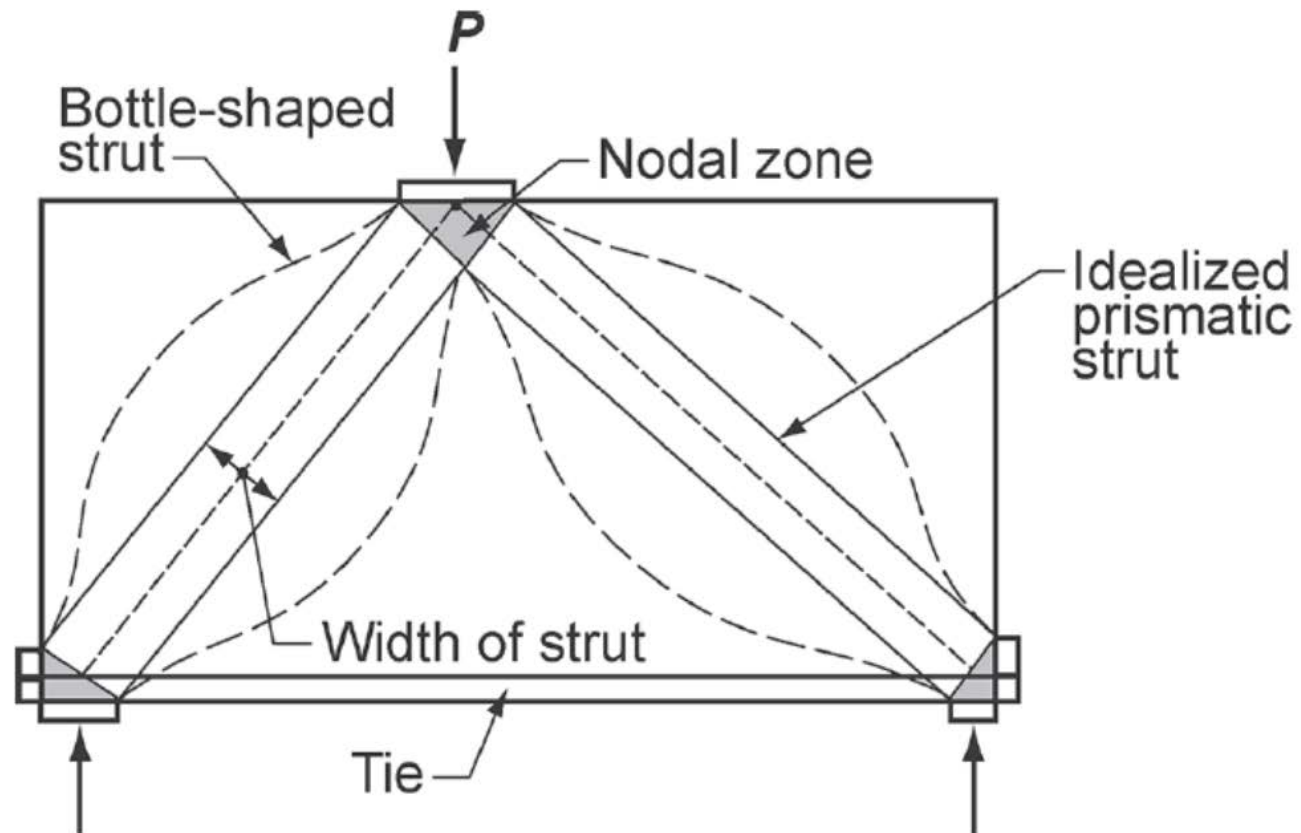
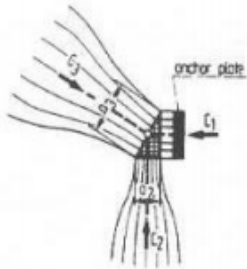

*Fig. R23.2.1—Description of strut-and-tie model.*

# Types of Discrete Nodes

From Schliach, et. al.:

a) CCC Nodes



c) CTT Nodes

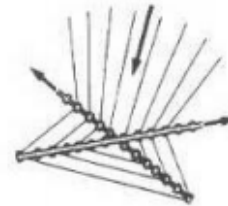

b) CCT Nodes

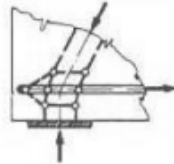
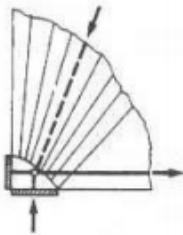

d) TTT Nodes

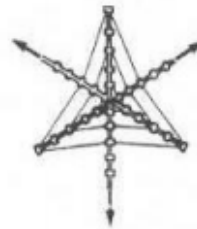

# Smearred Nodes

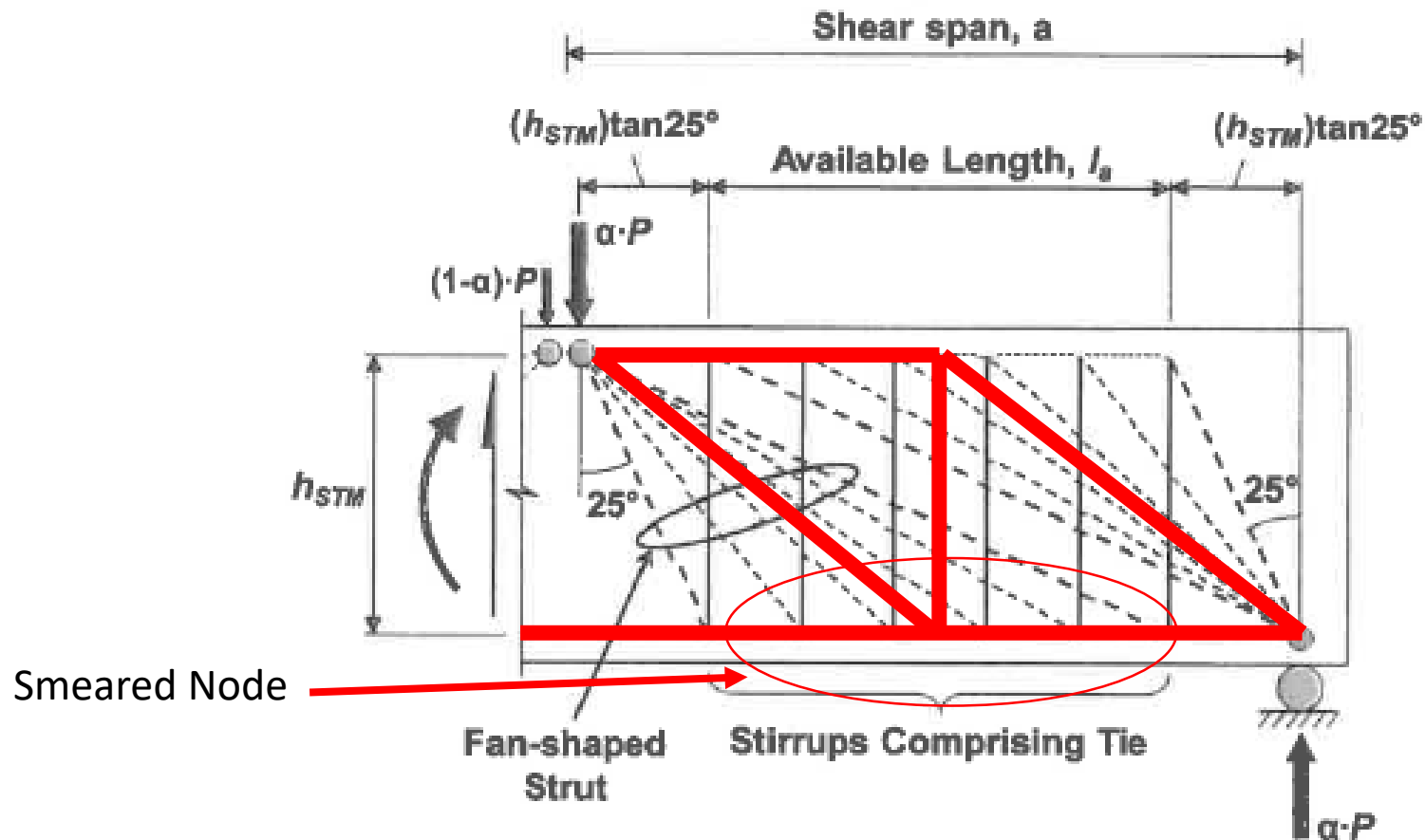

Figure C5.8.2.2-2—Fan-shaped Strut Engaging Transverse Reinforcement Forming a Tie

# Types of Struts:

From Schliach, et. al.:



*a) Prism*

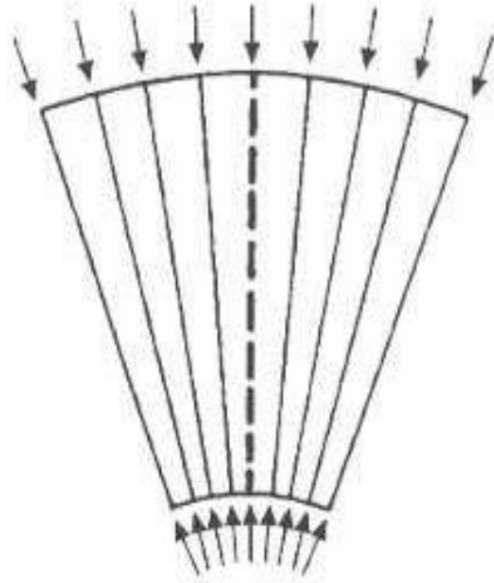

*b) Fan*

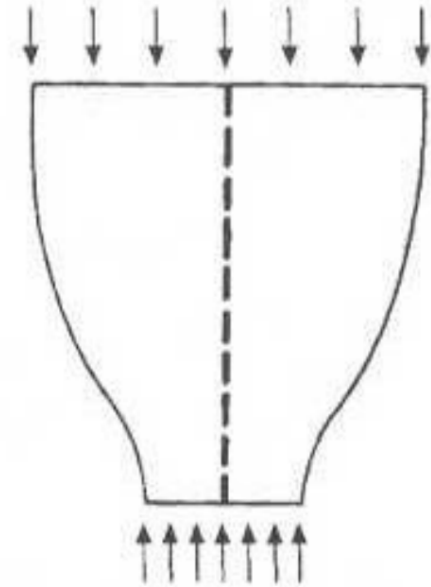

*c) Bottle*

# Strut-and-Tie Model Development:

## Model Components:

- Concrete Compression Struts
- Tension Ties – Mild or Post-Tensioned Reinforcement
- Connection or Bearing Nodes

# Strut-and-Tie Model Development:

- Model should follow the Elastic Stress Distribution
- Strut-and-Tie models are based on Lower Bound Theory of Plasticity.
- Models satisfy equilibrium and materials are elastic-perfectly plastic
- This requires that reinforcement **MUST** yield prior to concrete crushing (Concrete is **NOT** perfectly plastic!)

# Strut-and-Tie Model Development:

- Tension in concrete is neglected
- Struts and Ties are uni-axial
- External Forces must be applied at nodes

# Strut-and-Tie Model Development:

- Models should not be hyper-static:

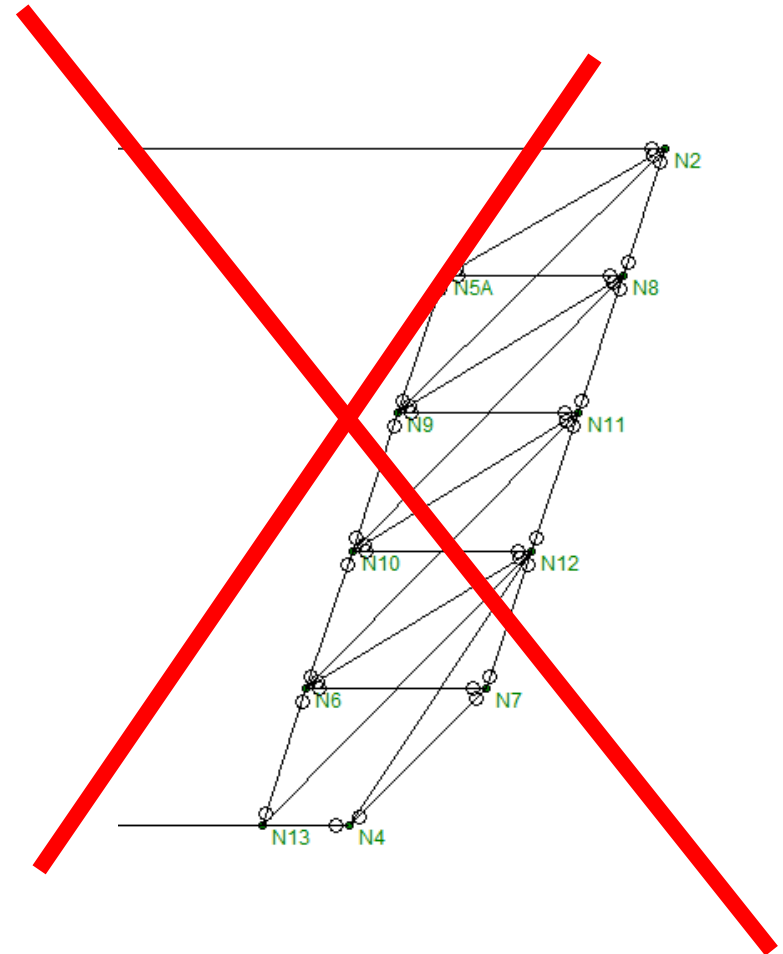
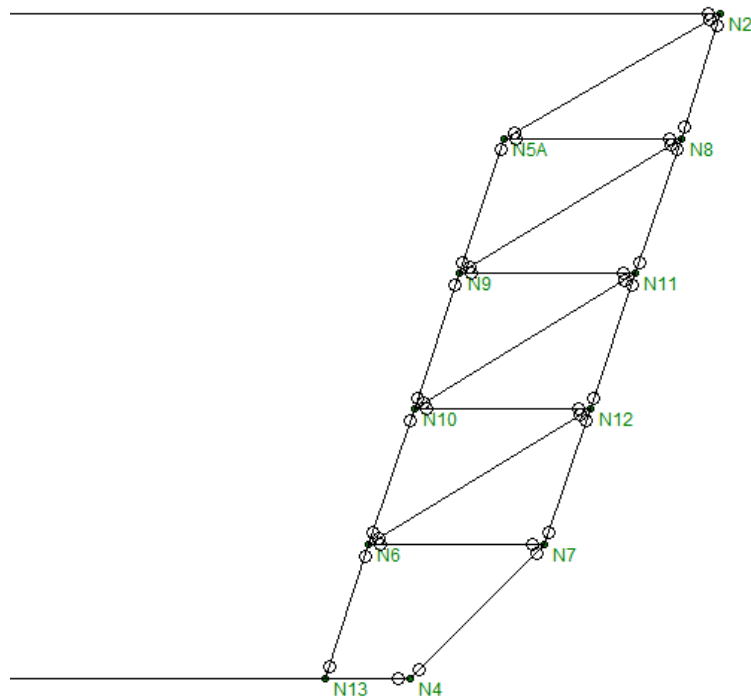

# Strut-and-Tie Model Development:

## Steps for model Development:

- (1) Define and isolate each D-region.
- (2) Calculate resultant forces on each D-region boundary.
- (3) Select the model and compute the forces in the struts and ties to transfer the resultant forces across the D-region. The axes of the struts and ties are chosen to approximately coincide with the axes of the compression and tension fields, respectively.
- (4) Design the struts, ties, and nodal zones so that they have sufficient strength. Widths of struts and nodal zones are determined considering the effective concrete strengths defined in 23.4.3 and 23.9.2. Reinforcement is provided for the ties considering the steel strengths defined in 23.7.2. The reinforcement should be anchored in or beyond the nodal zones.

The basic steps in the STM may be taken as:

1. Determine the locations of the B- and D-Regions.
2. Define load cases.
3. Analyze structural components.
4. Size structural components using the shear serviceability check, given by Eq. C5.8.2.2-1.
5. Develop a strut-and-tie model. See Article 5.8.2.2.
6. Proportion ties.
7. Perform nodal strength checks. See Article 5.8.2.5.
8. Proportion crack control reinforcement. See Article 5.8.2.6.
9. Provide necessary anchorage for ties.



# Design Example #1

Identify D and B Regions

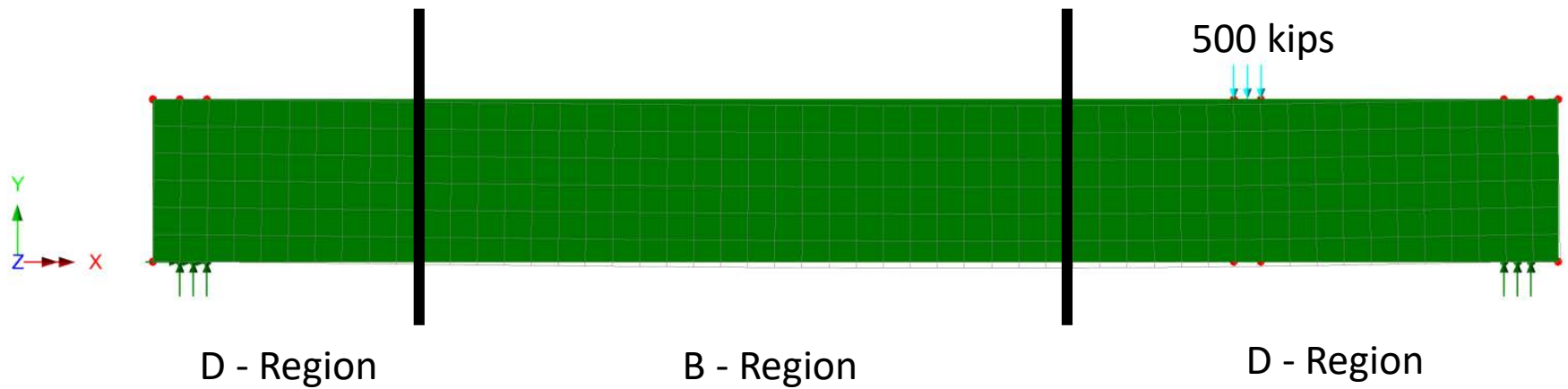

# Design Example #1

## Deep Beam

Analysis: Analysis 1  
Loadcase: 1:Loadcase 1  
Results file: design\_ex\_1~Analysis 1.mys  
Entity: Stress (middle) - Thick Shell  
Component: SE (Units: N/m<sup>2</sup>)

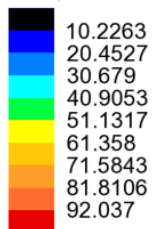

Maximum 92.1044 at node 101  
Minimum 0.0674707 at node 1053

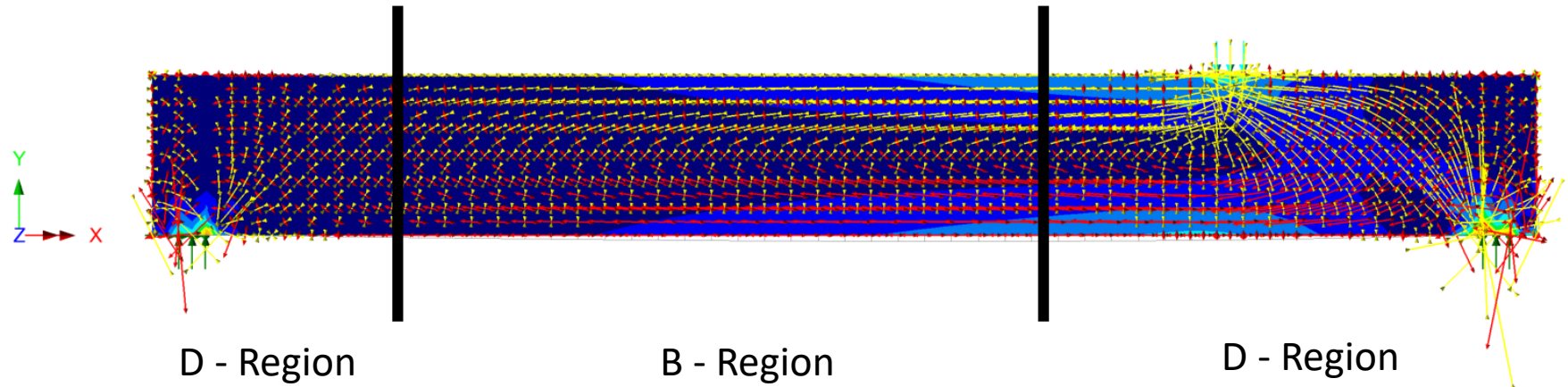

# Design Example #1

## Deep Beam Principle Stress Vectors

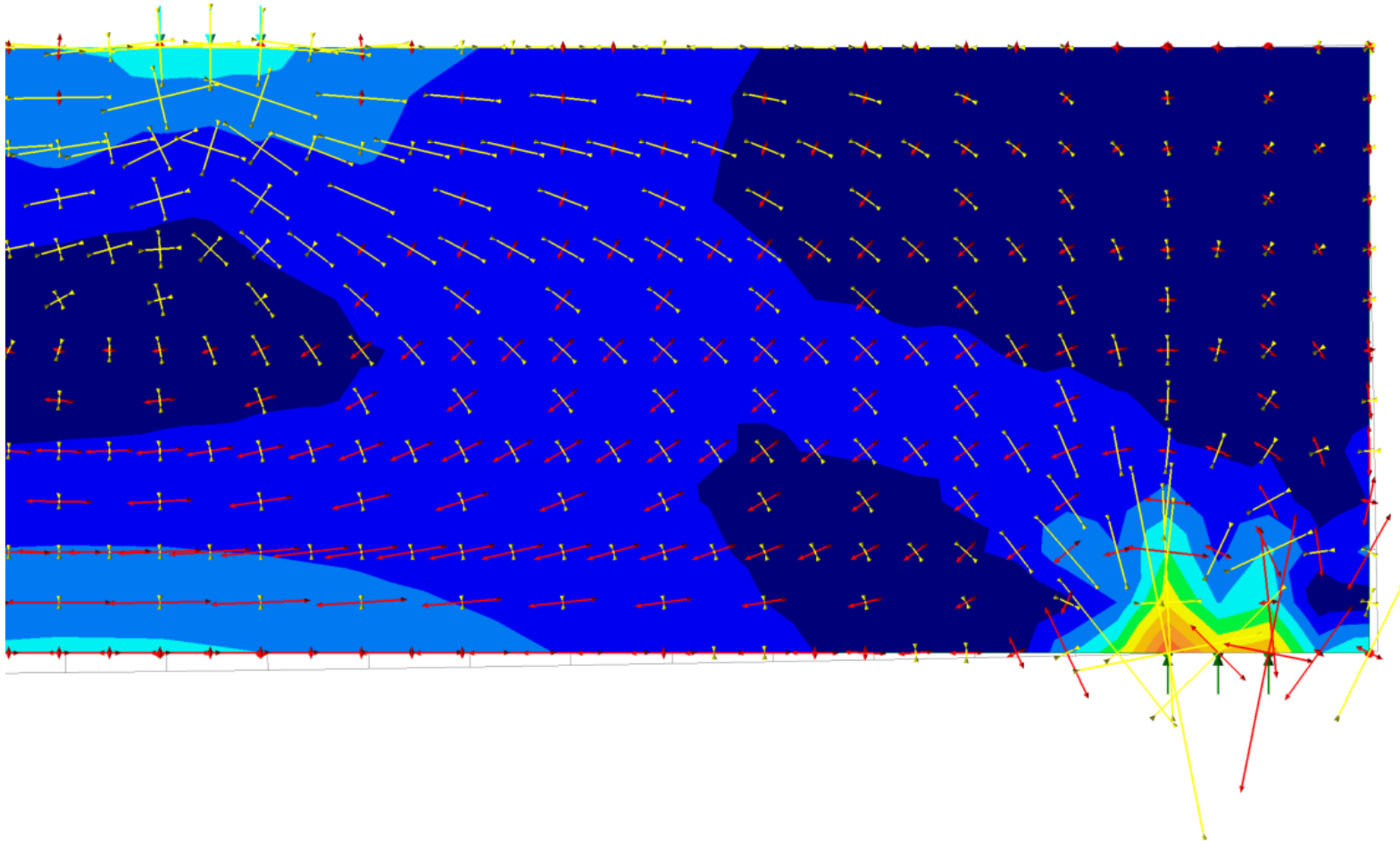

# Design Example #1

## Deep Beam

Bottle Shaped Strut

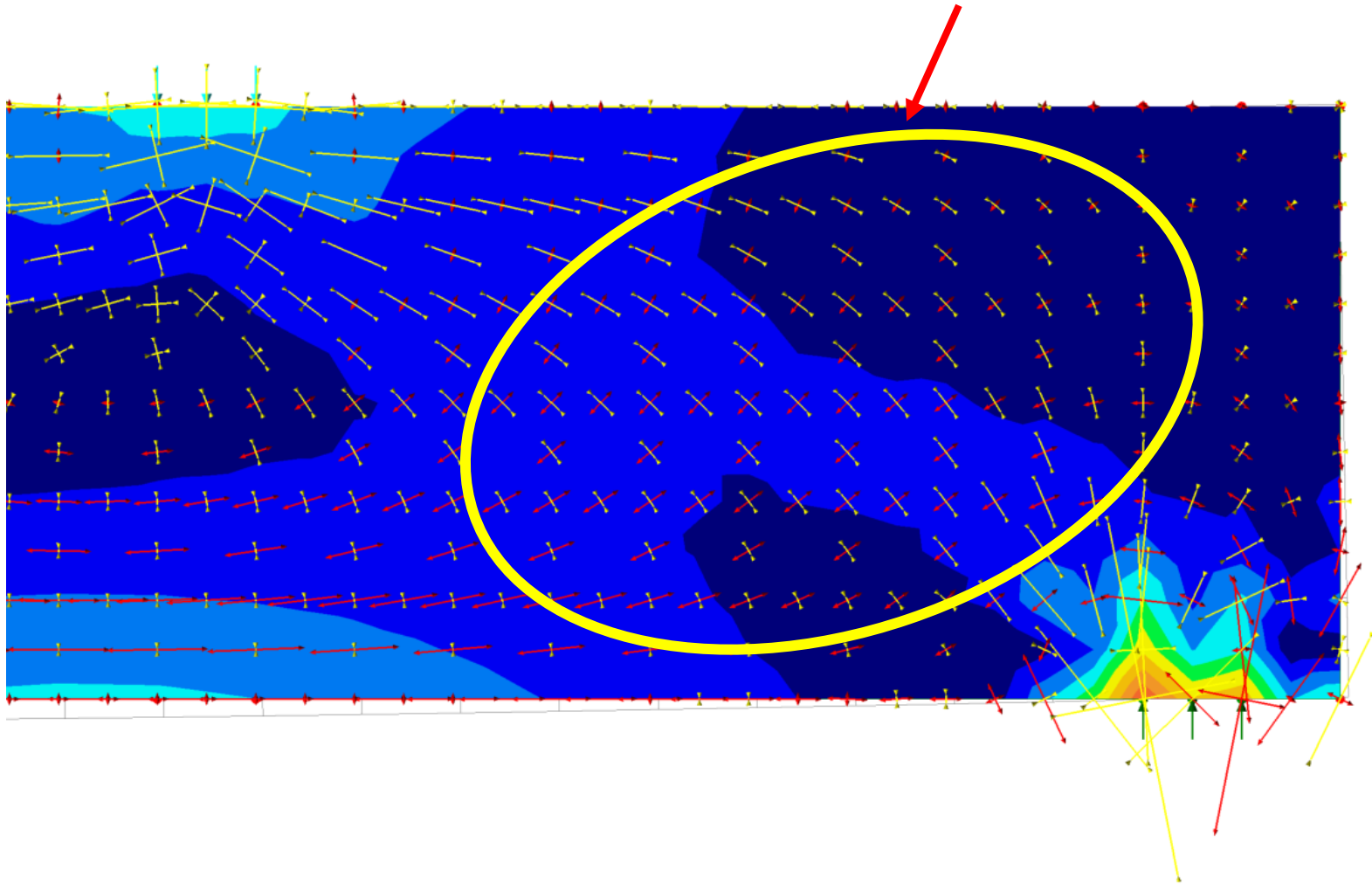

# Design Example #1

Identify Compression Struts and Tension Ties

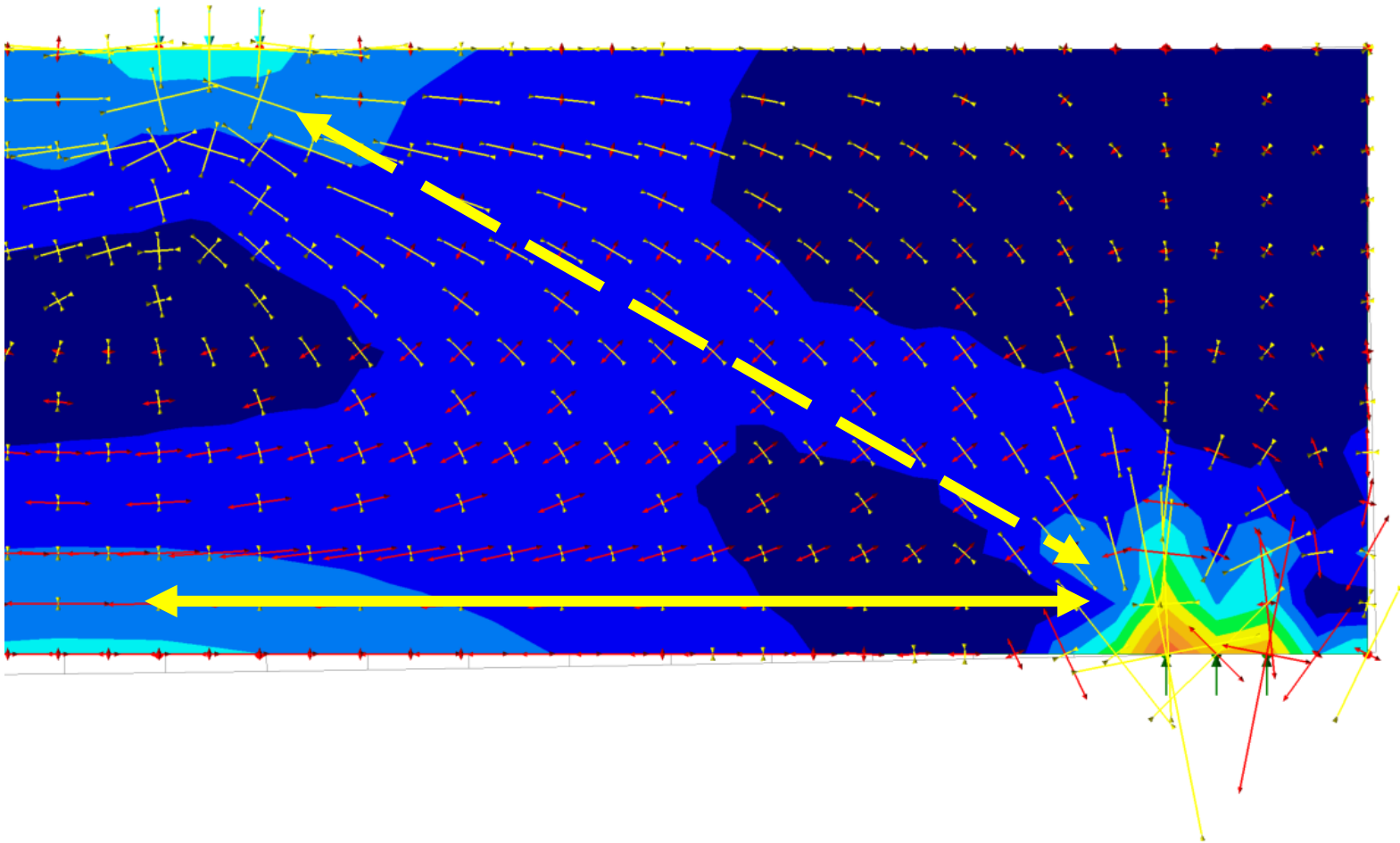

# Design Example #1

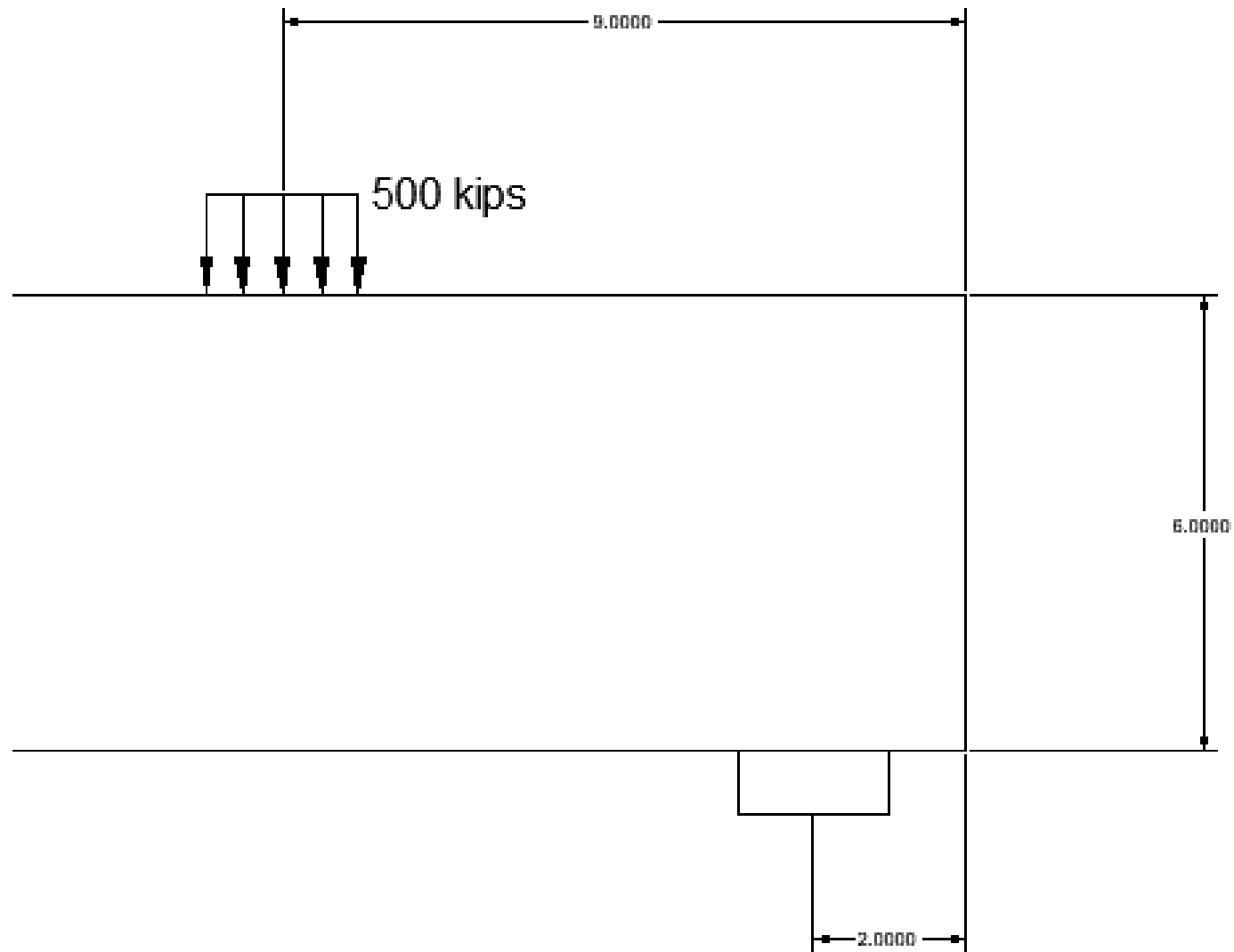

# Design Example #1

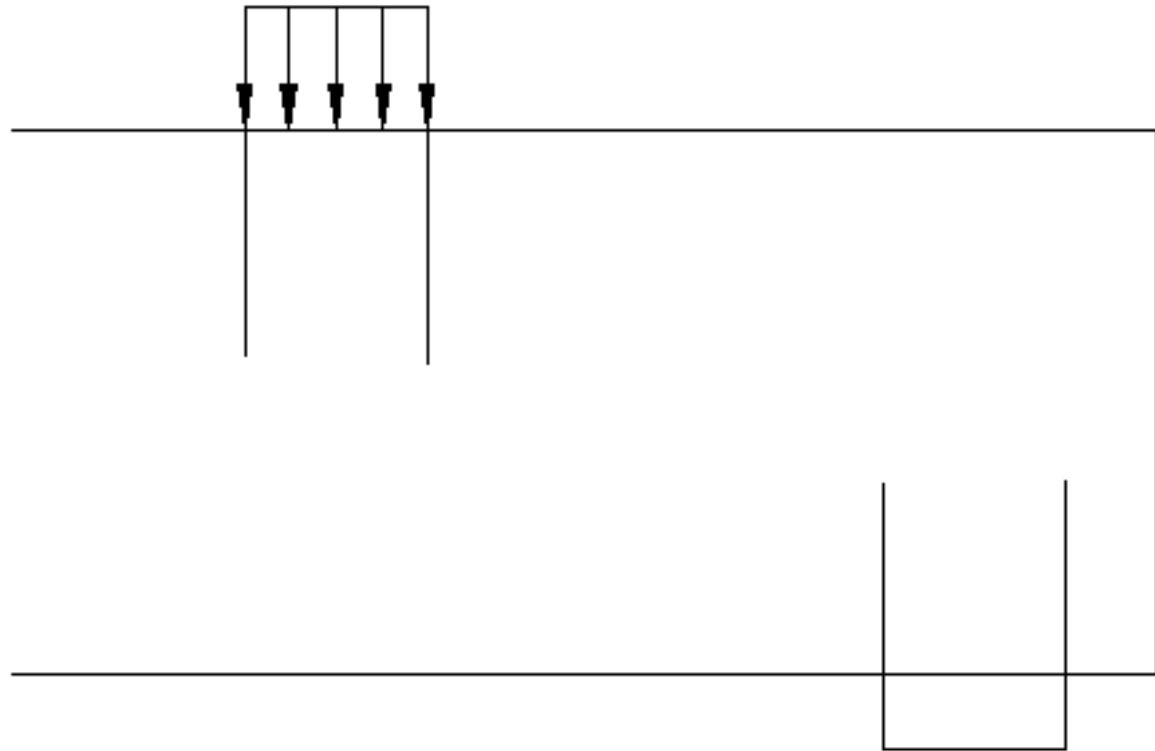

# Design Example #1

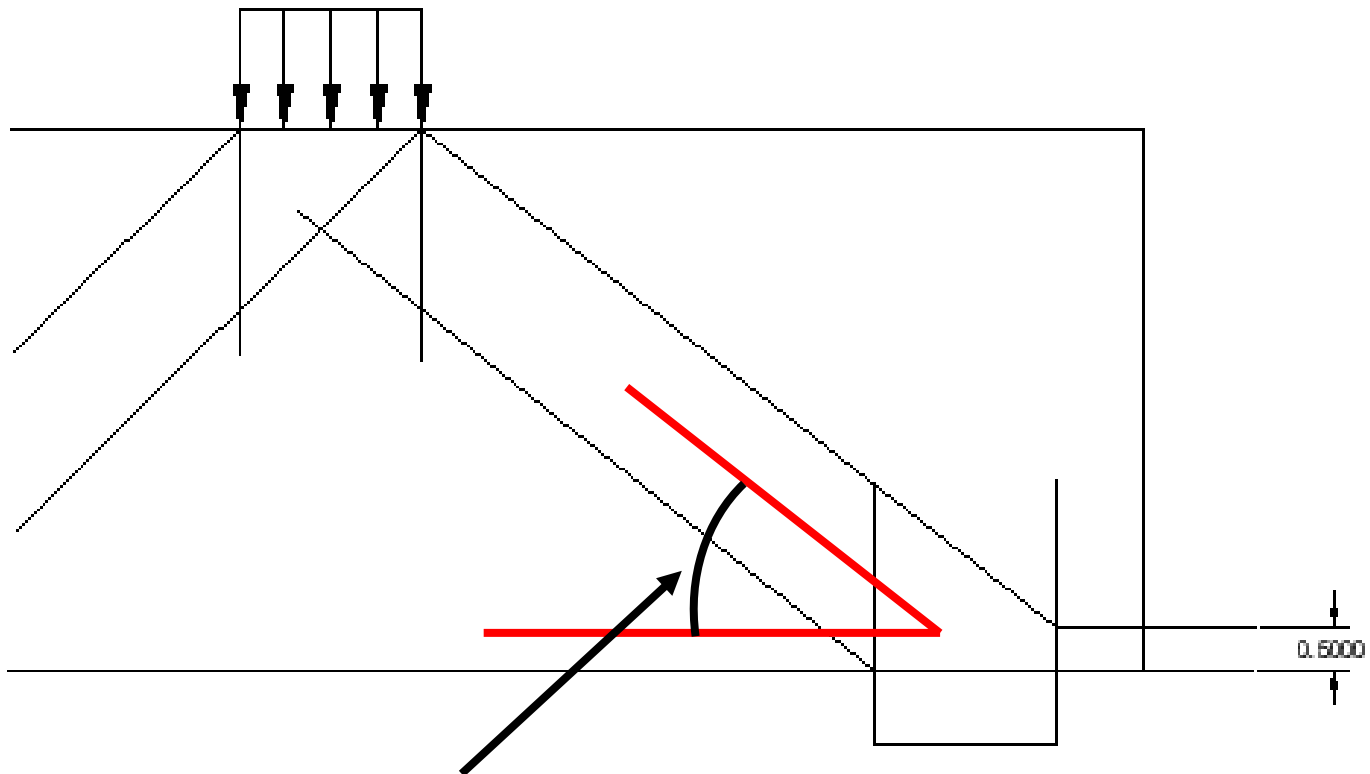

Strut/Tie Angles must be  $> 25$  degrees

# Design Example #1

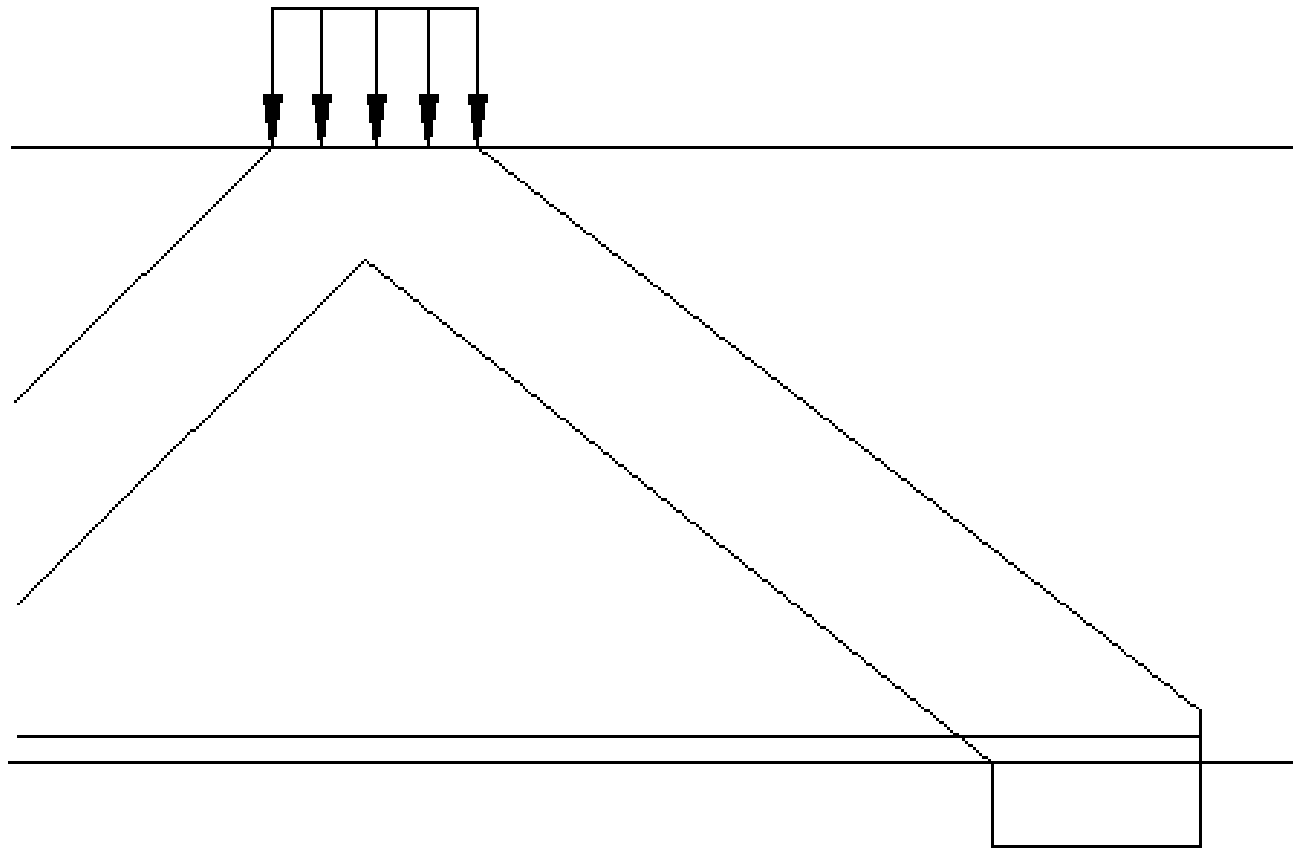

# Design Example #1

## RISA STM

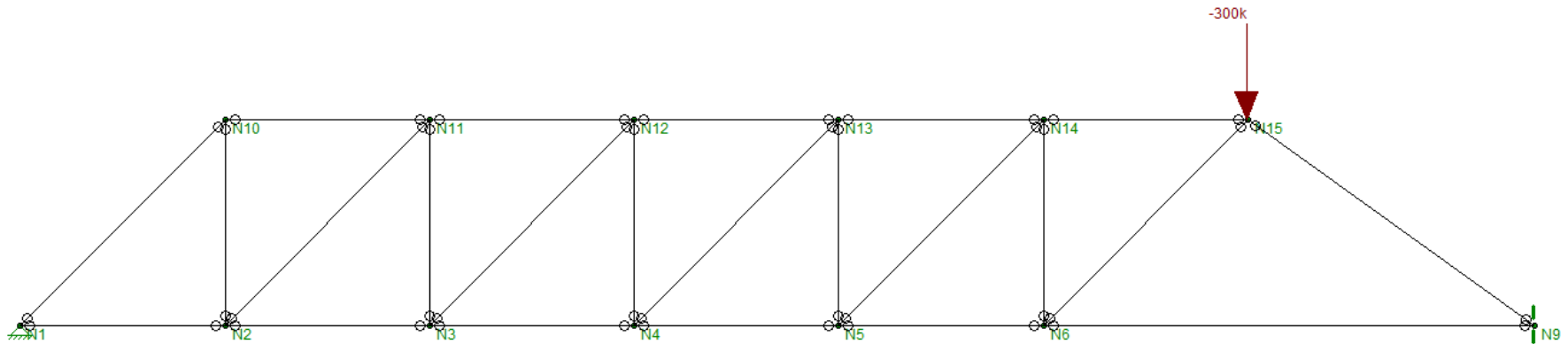



# Design Example #1

Analysis Results:

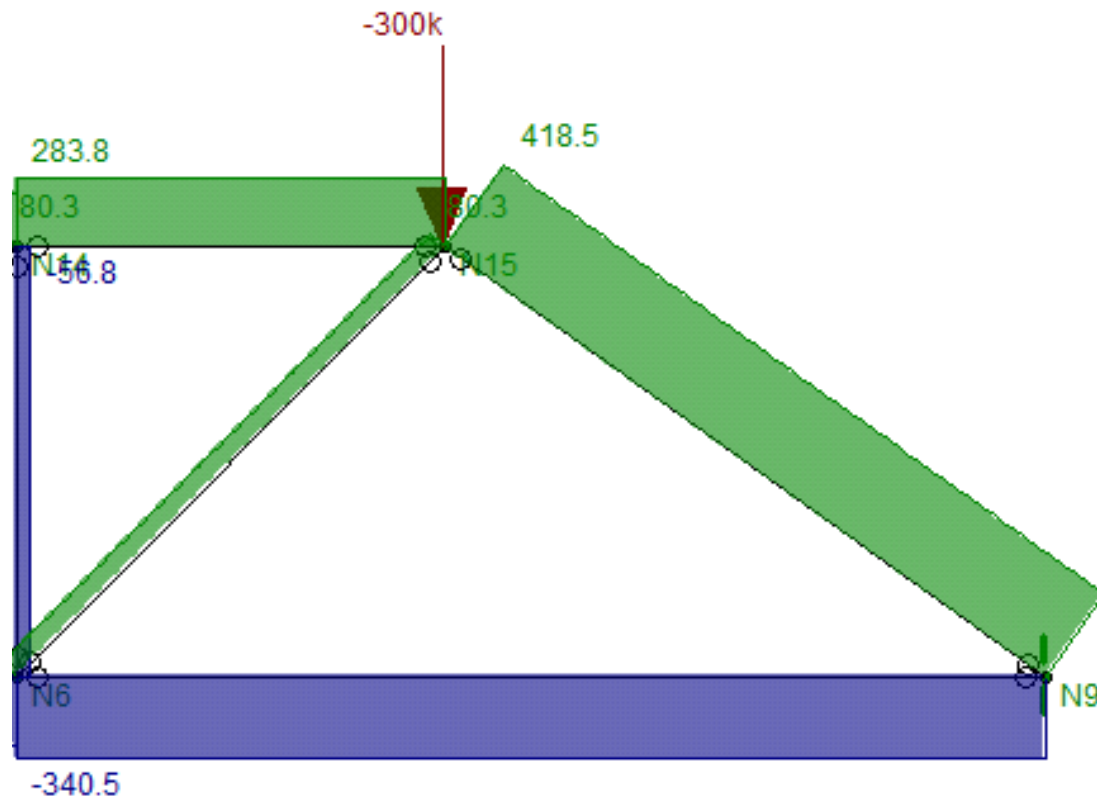

# Design Example #1

Tension Tie Design:

$T = 341$  kips

$F_y = 60$  ksi

Beam Width = 24"

*ACI 5.5.4.2*

$$\phi = 0.75$$

$$A_s = 341 \text{ kips} / (0.75 * 60 \text{ ksi})$$

$$= 7.58 \text{ in}^2$$

Use: 4X2 #9 bars,  $A_s = 8.00 \text{ in}^2$

*AASHTO 5.5.4.2*

$$\phi = 0.90$$

$$A_s = 341 \text{ kips} / (0.9 * 60 \text{ ksi})$$

$$= 6.31 \text{ in}^2$$

Use: 4X2 #8 bars,  $A_s = 6.32 \text{ in}^2$

# Design Example #1

Diagonal Strut Check at Bearing Node:

$C = 419$  kips

$F_y = 5$  ksi

Beam Width = 24"

Strut Thickness = 19.5"

CCT Node

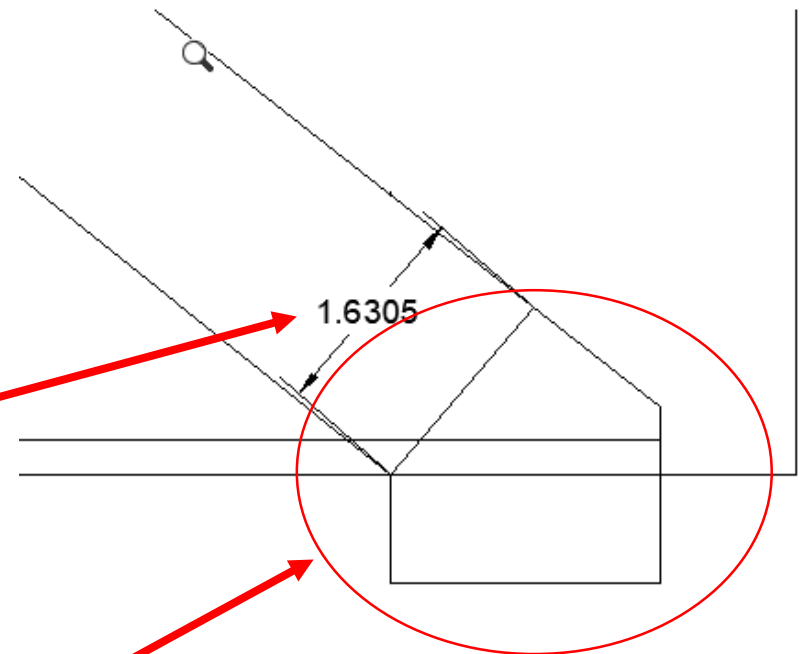

# Strut-and-Tie Model Detailing:

Extended Nodal Region: Check Reinforcement anchorage into nodal region

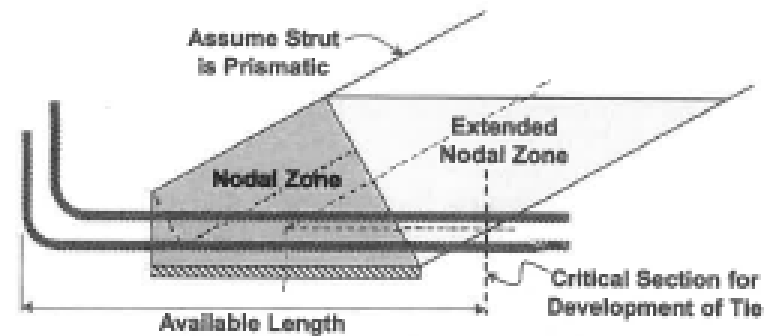
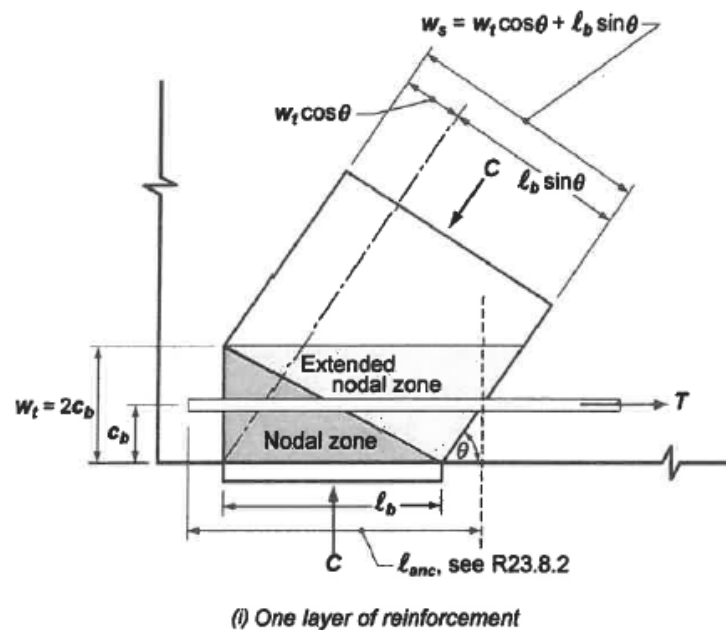
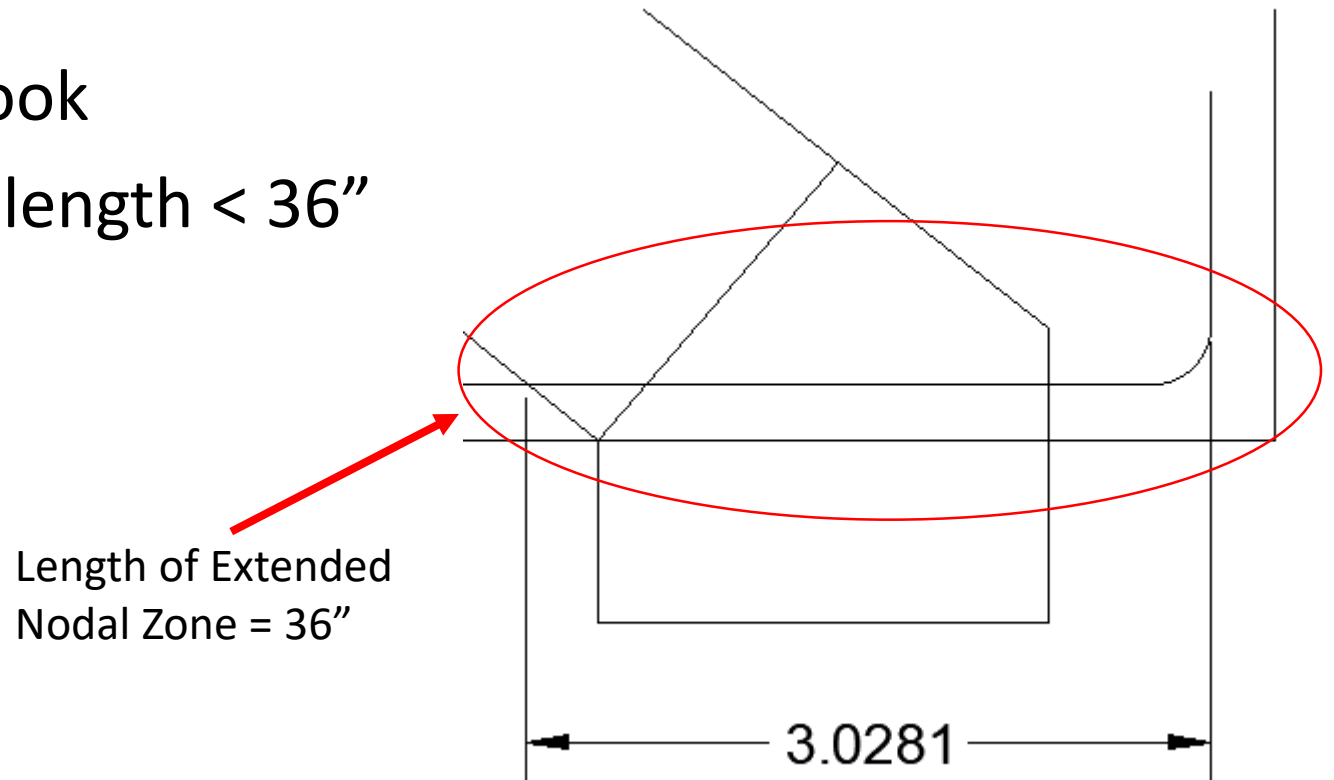

Figure C5.8.2.4.2-1—Available Development Length for Ties

# Strut-and-Tie Model Detailing:

Extended Nodal Region: Check Reinforcement anchorage into nodal region

- Check that hook development length  $< 36''$



# Design Example #1

## 23.9—Strength of nodal zones

**23.9.1** The nominal compressive strength of a nodal zone,  $F_{nn}$ , shall be calculated by:

$$F_{nn} = f_{ce} A_{nz} \quad (23.9.1)$$

where  $f_{ce}$  is defined in 23.9.2 or 23.9.3 and  $A_{nz}$  is given in 23.9.4 or 23.9.5.

**23.9.2** The effective compressive strength of concrete at a face of a nodal zone,  $f_{ce}$ , shall be calculated by:

$$f_{ce} = 0.85\beta_n f'_c \quad (23.9.2)$$

where  $\beta_n$  shall be in accordance with Table 23.9.2.

**Table 23.9.2—Nodal zone coefficient  $\beta_n$**

Configuration of nodal zone	$\beta_n$	
Nodal zone bounded by struts, bearing areas, or both	1.0	(a)
Nodal zone anchoring one tie	0.80	(b)
Nodal zone anchoring two or more ties	0.60	(c)

## 5.8.2.5.3—Limiting Compressive Stress at the Node Face

### 5.8.2.5.3a—General

Unless confinement reinforcement is provided and its effect is supported by analysis or experimentation, the limiting compressive stress at the node face,  $f_{cn}$ , shall be taken as:

$$f_{cn} = mvf'_c \quad (5.8.2.5.3a-1)$$

where:

- $f'_c$  = compressive strength of concrete for use in design (ksi)
- $m$  = confinement modification factor, taken as  $\sqrt{A_2/A_1}$  but not more than 2.0 as defined in Article 5.6.5
- $\nu$  = concrete efficiency factor:
  - 0.45, structures that do not contain crack control reinforcement as specified in Article 5.8.2.6;
  - as shown in Table 5.8.2.5.3a-1 for structures with crack control reinforcement as specified in Article 5.8.2.6
- $A_1$  = area under the bearing device (in.<sup>2</sup>)
- $A_2$  = notional area specified in Article 5.6.5 (in.<sup>2</sup>)

In addition to satisfying strength criteria, the node regions shall be designed to comply with the stress and anchorage limits specified in Articles 5.8.2.4.1 and 5.8.2.4.2.

# Design Example #1

Table 5.8.2.5.3a-1—Efficiency Factors for Nodes with Crack Control Reinforcement

Face	Node Type		
	CCC	CCT	CTT
Bearing Face			
Back Face	0.85	0.70	
	$0.85 - \frac{f'_c}{20 \text{ ksi}}$	$0.85 - \frac{f'_c}{20 \text{ ksi}}$	$0.85 - \frac{f'_c}{20 \text{ ksi}}$
Strut-to-Node Interface	$0.45 \leq v \leq 0.65$	$0.45 \leq v \leq 0.65$	$0.45 \leq v \leq 0.65$

# Design Example #1

*ACI Table 23.9.2*

$$\beta_n = 0.80$$

$$F_{nn} = 0.80 \times 0.85 \times 5\text{ksi} \times 24" \times 19.5"$$

$$\phi P = 1,591 \text{ kips} > 419 \text{ kips} \quad \text{OK}$$

*AASHTO Table 5.8.2.5.3a – 1*

$$v = 0.85 - \left(\frac{5\text{ksi}}{20\text{ksi}}\right)$$

$$= 0.60$$

*AASHTO 5.8.2.5.3a*

$$m = 1.0$$

*Strut width = Member Width*

Compute Strut Capacity:

$$\phi P = 0.60 \times 1.0 \times 5\text{ksi} \times 24" \times 19.5"$$

$$\phi P = 1,404 \text{ kips} > 419 \text{ kips} \quad \text{OK}$$

# Design Example #1

## 23.4—Strength of struts

**23.4.1** The nominal compressive strength of a strut,  $F_{ns}$ , shall be calculated by (a) or (b):

(a) Strut without longitudinal reinforcement

$$F_{ns} = f_{ce}A_{cs} \quad (23.4.1a)$$

(b) Strut with longitudinal reinforcement

$$F_{ns} = f_{ce}A_{cs} + A_s'f_s' \quad (23.4.1b)$$

where  $F_{ns}$  shall be evaluated at each end of the strut and taken as the lesser value;  $A_{cs}$  is the cross-sectional area at the end of the strut under consideration;  $f_{ce}$  is given in 23.4.3;  $A_s'$  is the area of compression reinforcement along the length of the strut; and  $f_s'$  is the stress in the compression reinforcement at the nominal axial strength of the strut. It shall be permitted to take  $f_s'$  equal to  $f_y$  for Grade 40 or 60 reinforcement.

# Design Example #1

**23.4.3** Effective compressive strength of concrete in a strut,  $f_{ce}$ , shall be calculated by:

$$f_{ce} = 0.85\beta_s f'_c \quad (23.4.3)$$

where  $\beta_s$ , in accordance with Table 23.4.3, accounts for the effect of cracking and crack-control reinforcement on the effective compressive strength of the concrete.

**Table 23.4.3—Strut coefficient  $\beta_s$**

Strut geometry and location	Reinforcement crossing a strut	$\beta_s$	
Struts with uniform cross-sectional area along length	NA	1.0	(a)
Struts located in a region of a member where the width of the compressed concrete at midlength of the strut can spread laterally (bottle-shaped struts)	Satisfying 23.5	0.75	(b)
	Not satisfying 23.5	0.60 $\lambda$	(c)
Struts located in tension members or the tension zones of members	NA	0.40	(d)
All other cases	NA	0.60 $\lambda$	(e)

# Design Example #1

Check Strut Capacity:

*ACI Table 23.4.3*

$$\beta_s = 0.60$$

$$F_{ns} = 0.60 \times 0.85 \times 5 \text{ksi} \times 24" \times 19.5"$$

$$\phi P = 1,193 \text{ kips} > 419 \text{ kips} \quad \text{OK}$$

# Design Example #1

- Use local strut-and-tie models to design bottle shaped struts when  $f'_c > 6,000\text{psi}$ .

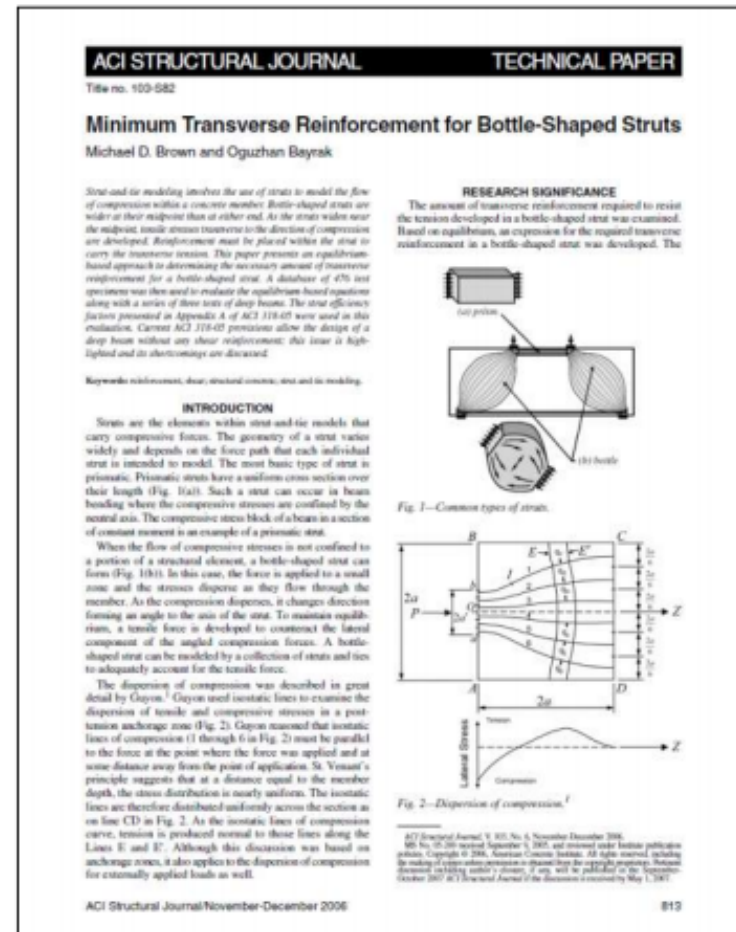

# Design Example #1

Checking of Compression Struts is critical maintain a valid STM load path:

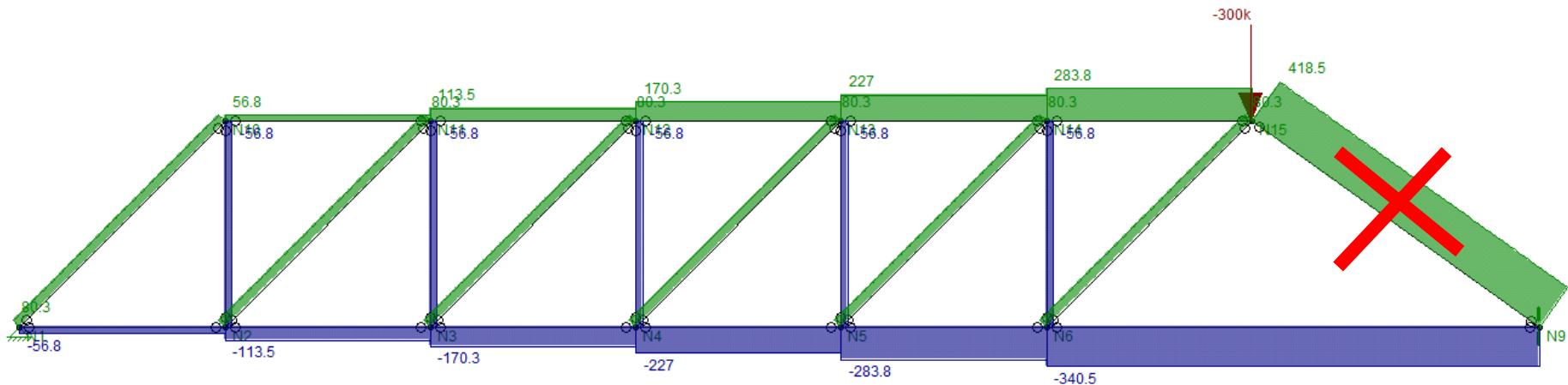

- Loss of one member = loss of entire structural system

# Design Example #1

## Detail Crack control Reinforcement:

### 5.8.2.6—Crack Control Reinforcement

Structures and components or regions thereof, except for slabs and footings, which have been designed using the efficiency factor of Table 5.8.2.5.3a-1, shall contain orthogonal grids of bonded reinforcement. The spacing of the bars in these grids shall not exceed the smaller of  $d/4$  and 12.0 in.

The reinforcement in the vertical direction shall satisfy the following:

$$\frac{A_v}{b_w s_v} \geq 0.003 \quad (5.8.2.6-1)$$

and the reinforcement in the horizontal direction shall satisfy the following:

$$\frac{A_h}{b_w s_h} \geq 0.003 \quad (5.8.2.6-2)$$

where:

- $A_h$  = total area of horizontal crack control reinforcement within spacing  $s_h$  (in.<sup>2</sup>)
- $A_v$  = total area of vertical crack control reinforcement within spacing  $s_v$  (in.<sup>2</sup>)
- $b_w$  = width of member's web (in.)
- $s_v, s_h$  = spacing of vertical and horizontal crack control reinforcement, respectively (in.)

# Reinforced Concrete Bridge Design

## Dapped Girder Strut-and-Tie Design:

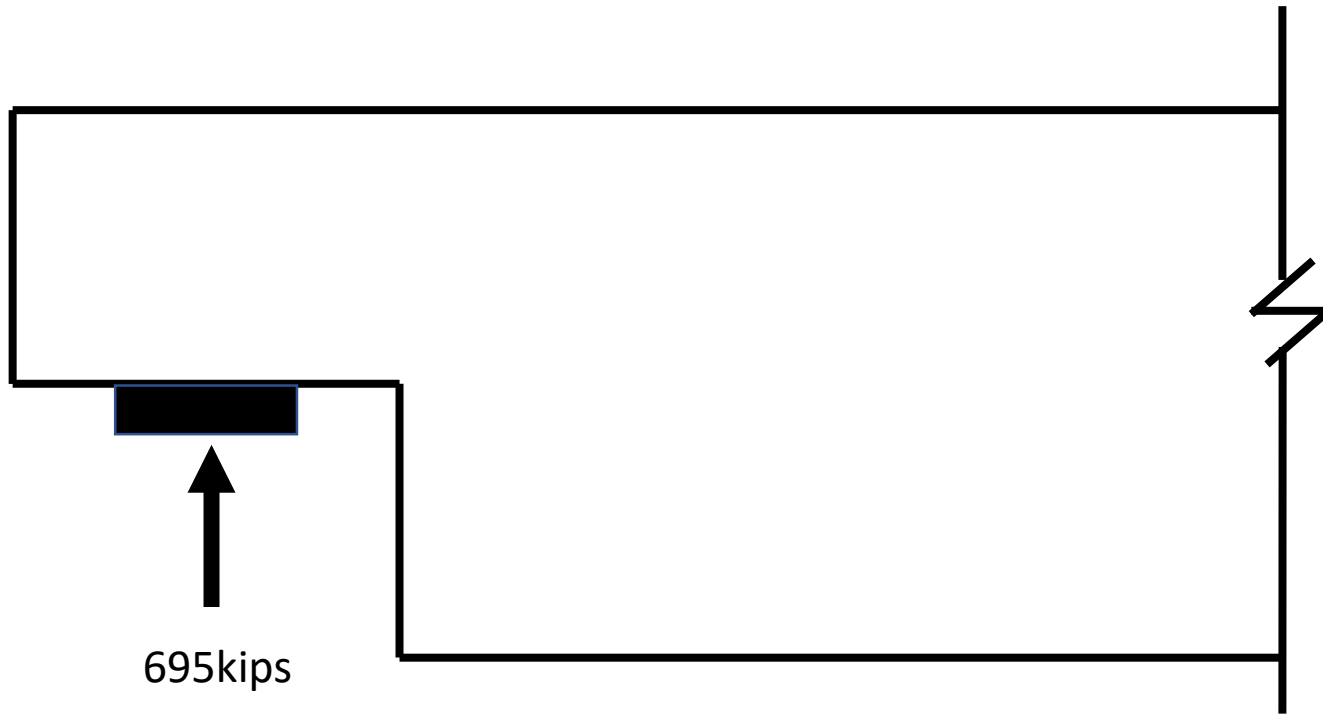

# Reinforced Concrete Bridge Design

## Dapped Girder Strut-and-Tie Design:

Behavior of dapped support

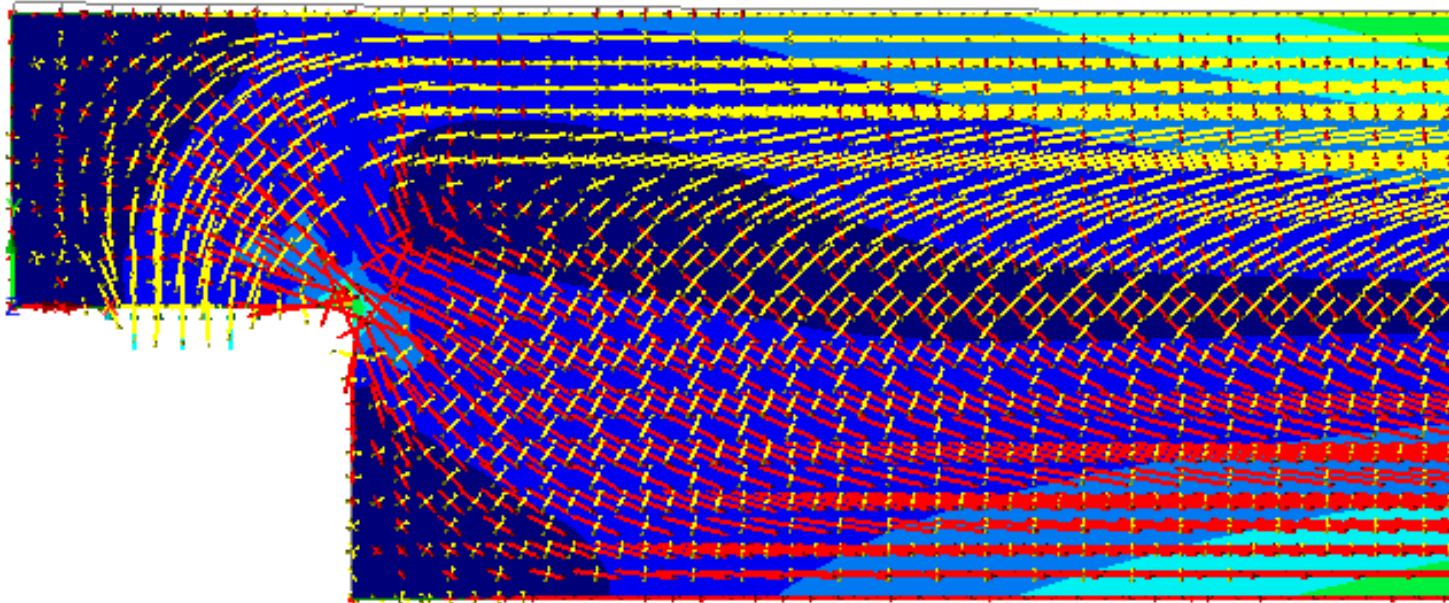



# Reinforced Concrete Bridge Design

## Potential Strut-and-Tie Models:

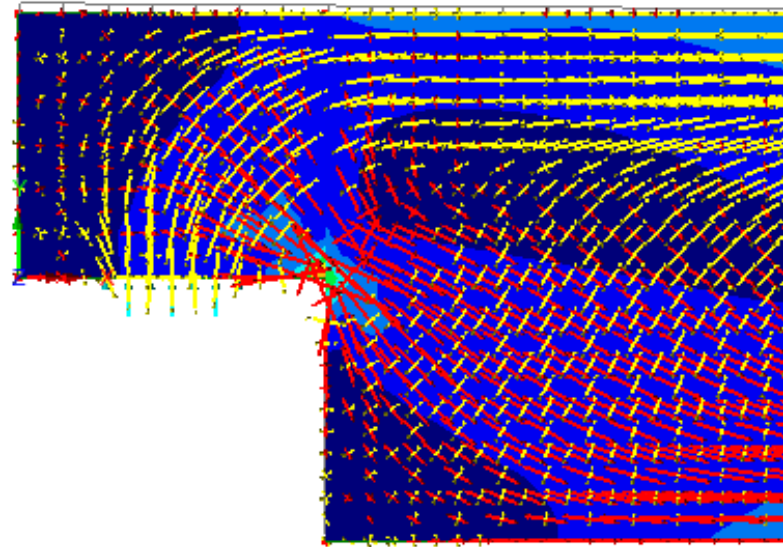
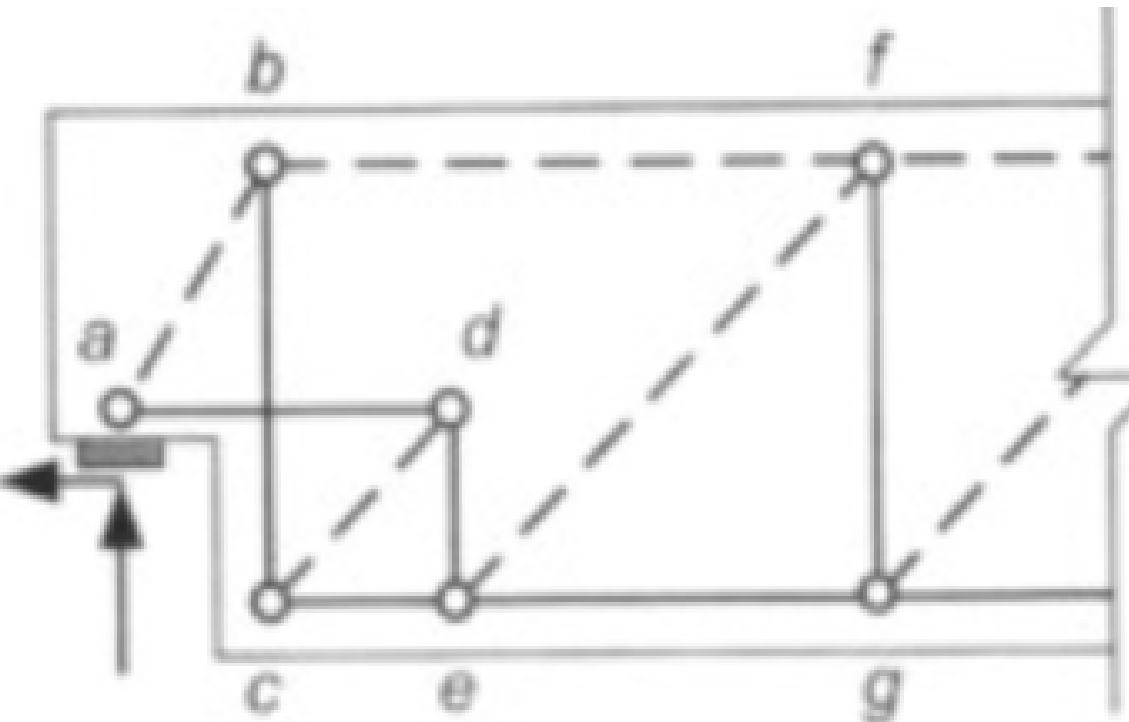

# Reinforced Concrete Bridge Design

## Potential Strut-and-Tie Models:

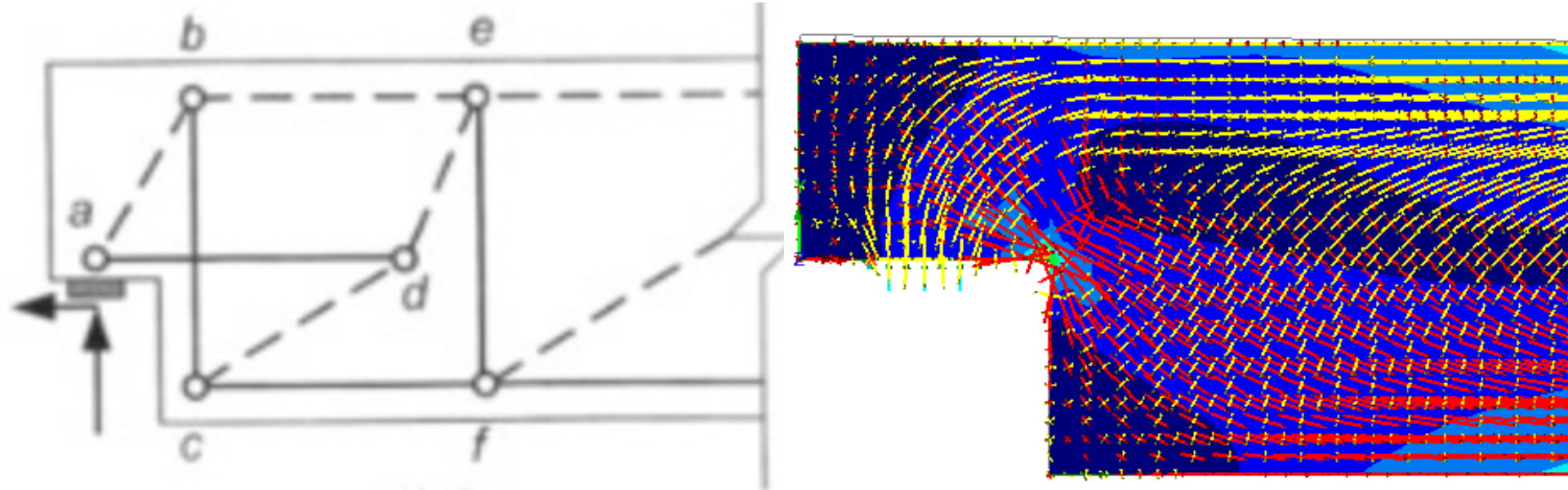

# Reinforced Concrete Bridge Design

## Dapped Girder Strut-and-Tie Design:

All models are valid, however, the best STM combines the following:

1. Closely follows the behavior of the elastic stresses
2. Closely follows a reasonable reinforcing pattern

# Reinforced Concrete Bridge Design

## Dapped Girder Strut-and-Tie Design:

Behavior of dapped support

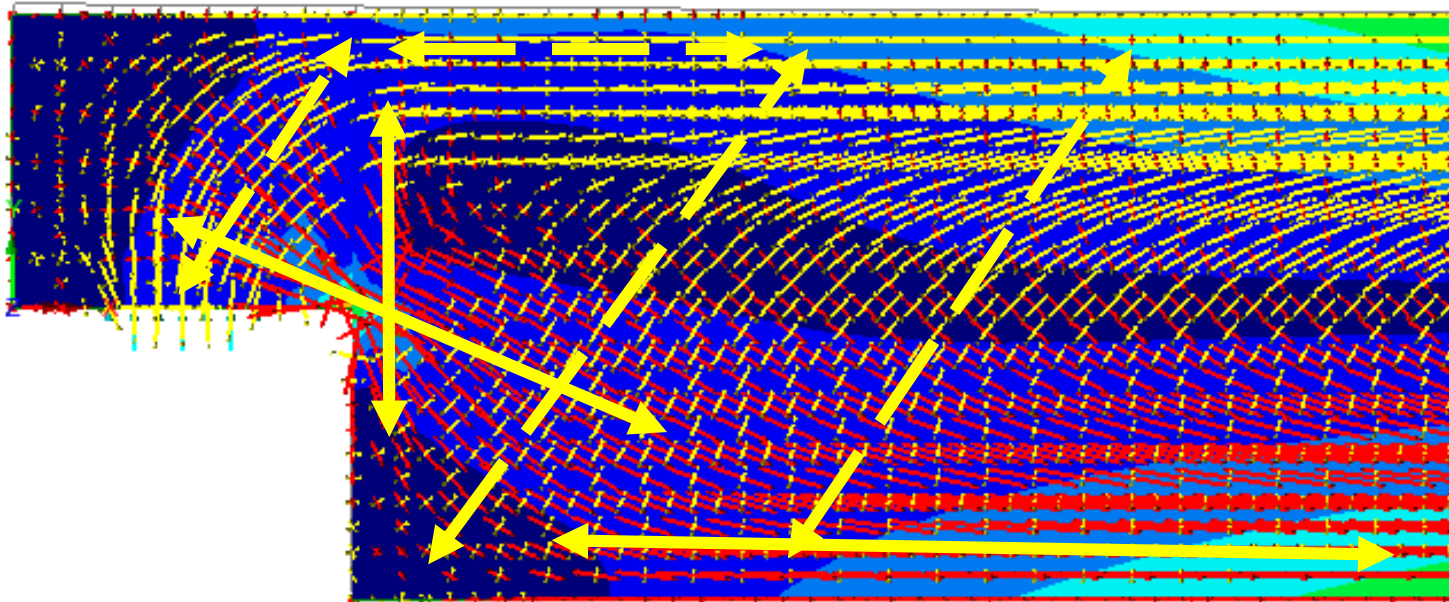

# Reinforced Concrete Bridge Design

## Dapped Girder Strut-and-Tie Design:

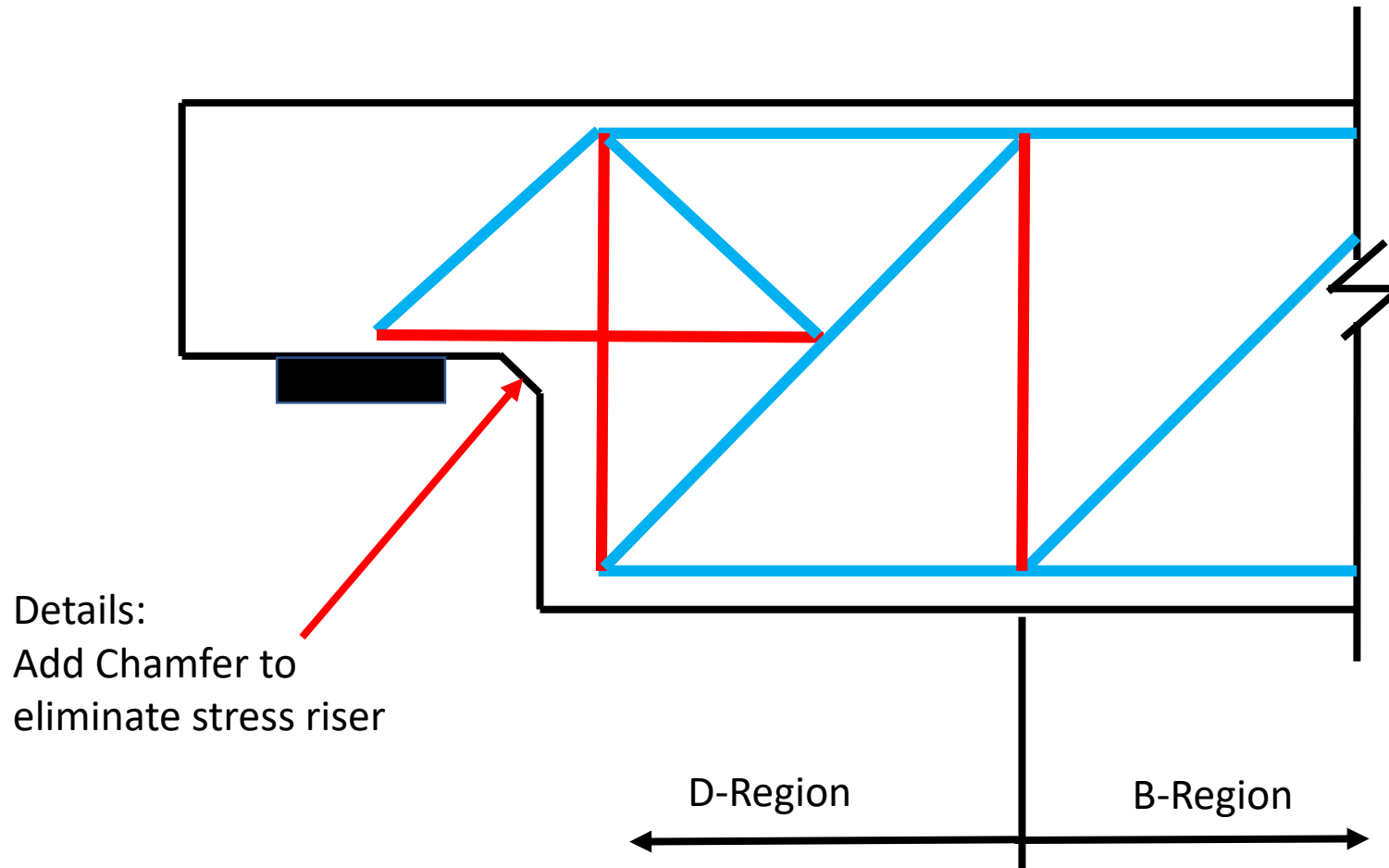

# Strut-and-Tie Model Development:

- STM should also be developed with the reinforcement pattern in mind.
- Example patterns from Schliach et. al

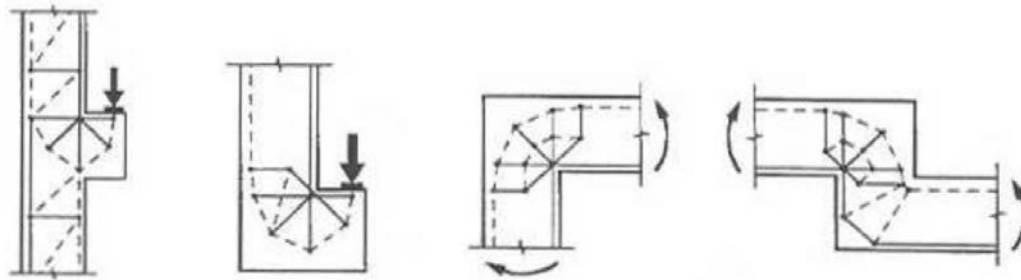

a) *Strut-and-Tie Model*

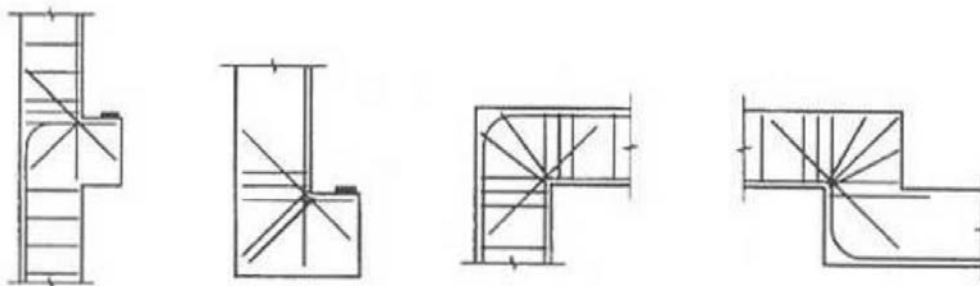

b) *Reinforcement*

# Strut-and-Tie Model Detailing:

Design Issue – What's wrong with this reinforcing detail?

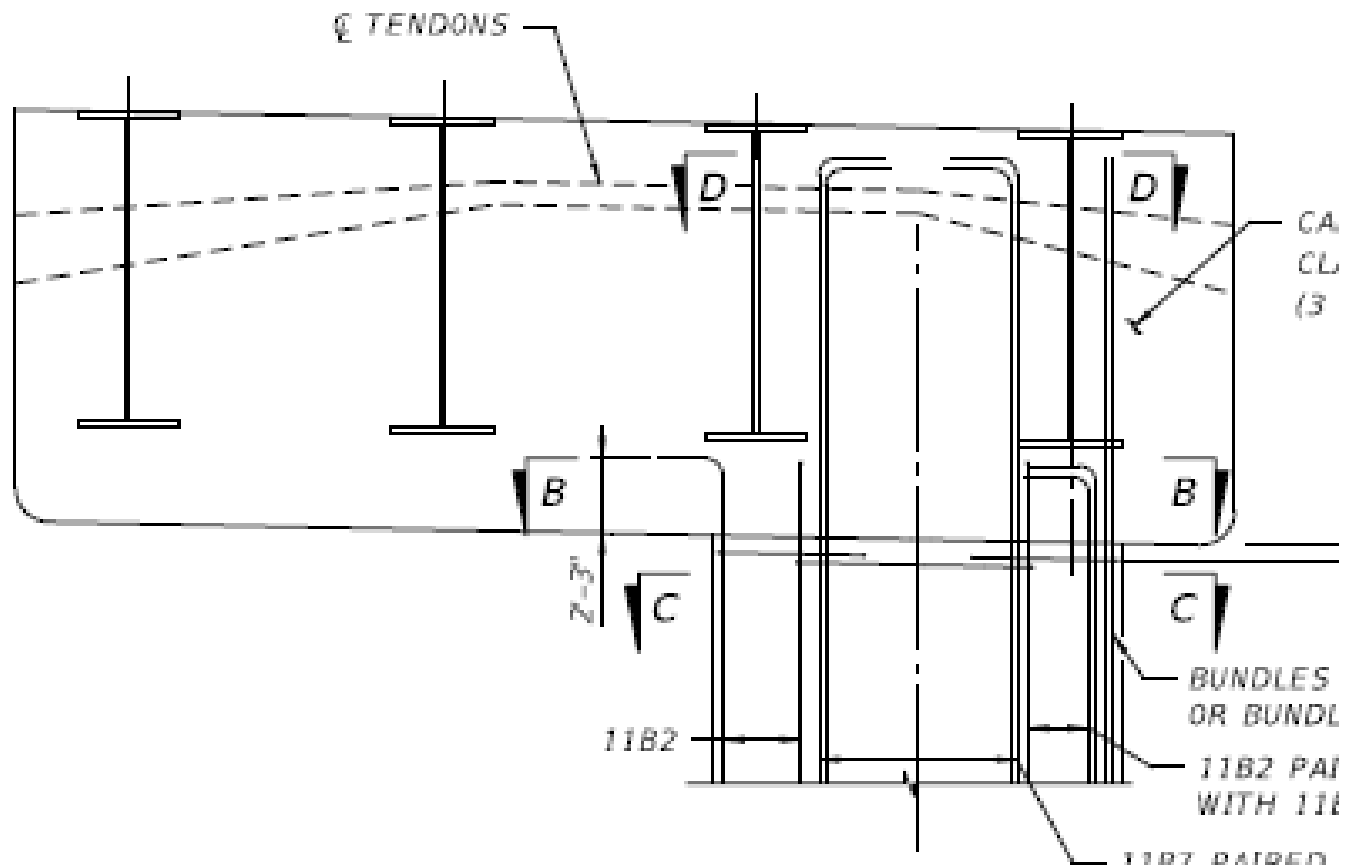

# Design Example #2

## Post-Tensioned Tension Ties

Check development of PT details

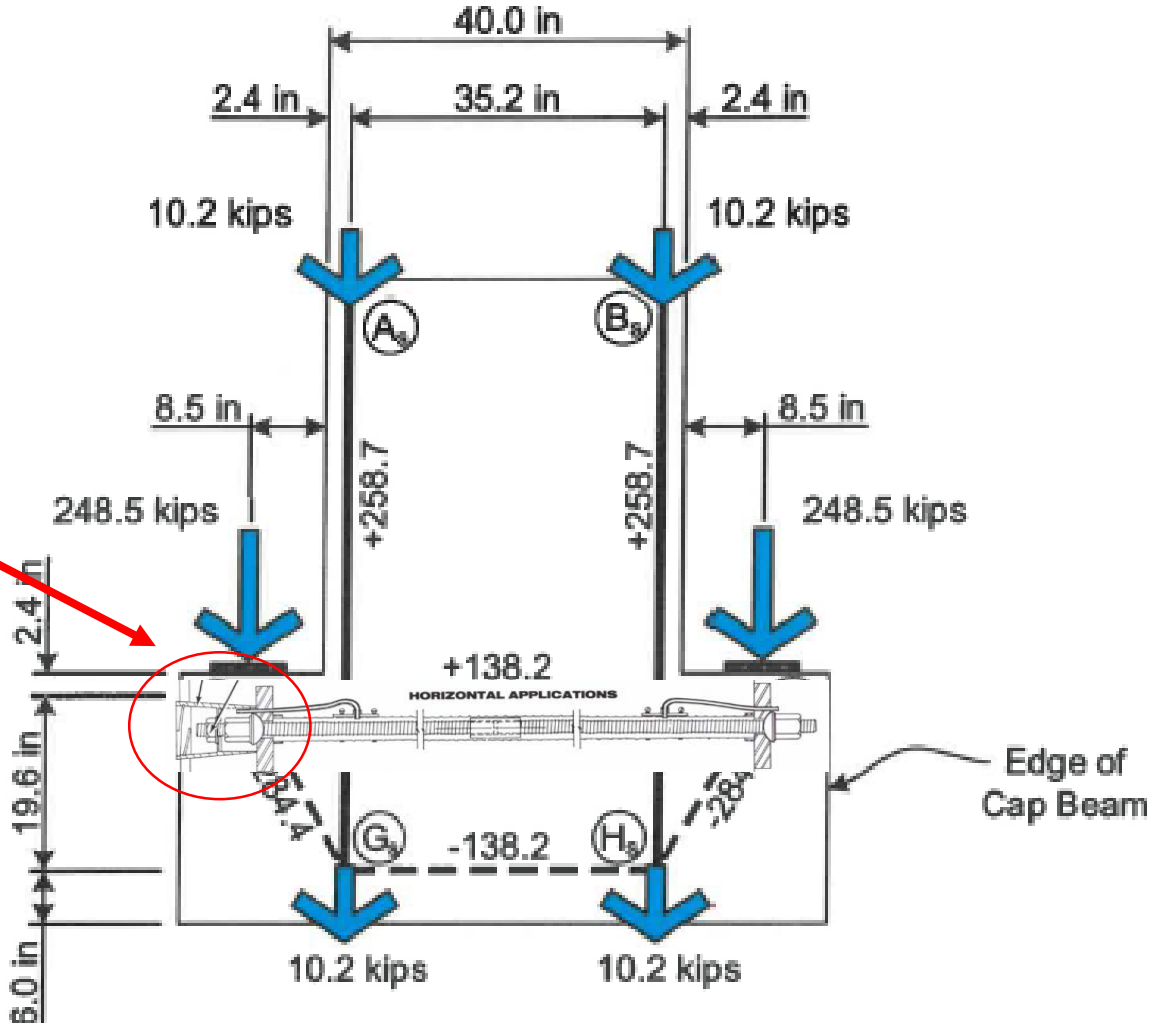

# Design Example #2

## Post-Tensioned Tension Ties

- Provides enhanced serviceability – PT force  $>$  permanent loading tie force
- Be careful with short bar lengths, the anchor set will reduce the effective PT force
- Recommend specifying final bar force, to be verified by lift-off.

# Design Example #2

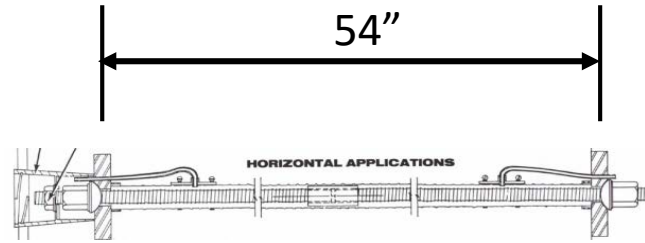

Example: Try 1 ¼" dia PT Bar      GUTS = 200kips

Max. stressing force = 80% \* 200 kips = 160 kips

Typical anchor set = 1/8" coarse threads, 1/16" fine threads

$$P_{eff} = 160 \text{ kips} - (0.125''/54'') * (1.25 \text{ in}^2 * 29,000 \text{ ksi})$$

$$= 160 - 84 \text{ kips}$$

$$= 76 \text{ kips (38 ksi)}$$

Less than half the stressing force!

# Design Example #2

*ACI 23.7*

$$\phi F_{nt} = 0.75 * 2.0 \text{ in}^2 * (38 * \text{ksi} + 60 * \text{ksi})$$

$$= 147 \text{ kips} > 138.2 \text{ kips} \quad \text{OK}$$

*AASHTO 5.8.2.4*

Fy of mild reinforcement

$$\phi P_n = 0.90 * 2.0 \text{ in}^2 * (38 * \text{ksi} + 60 * \text{ksi})$$

$$= 176 \text{ kips} > 138.2 \text{ kips} \quad \text{OK}$$

# Strut-and-Tie Model Detailing:

Design Issue – What's wrong with this PT bar detail?

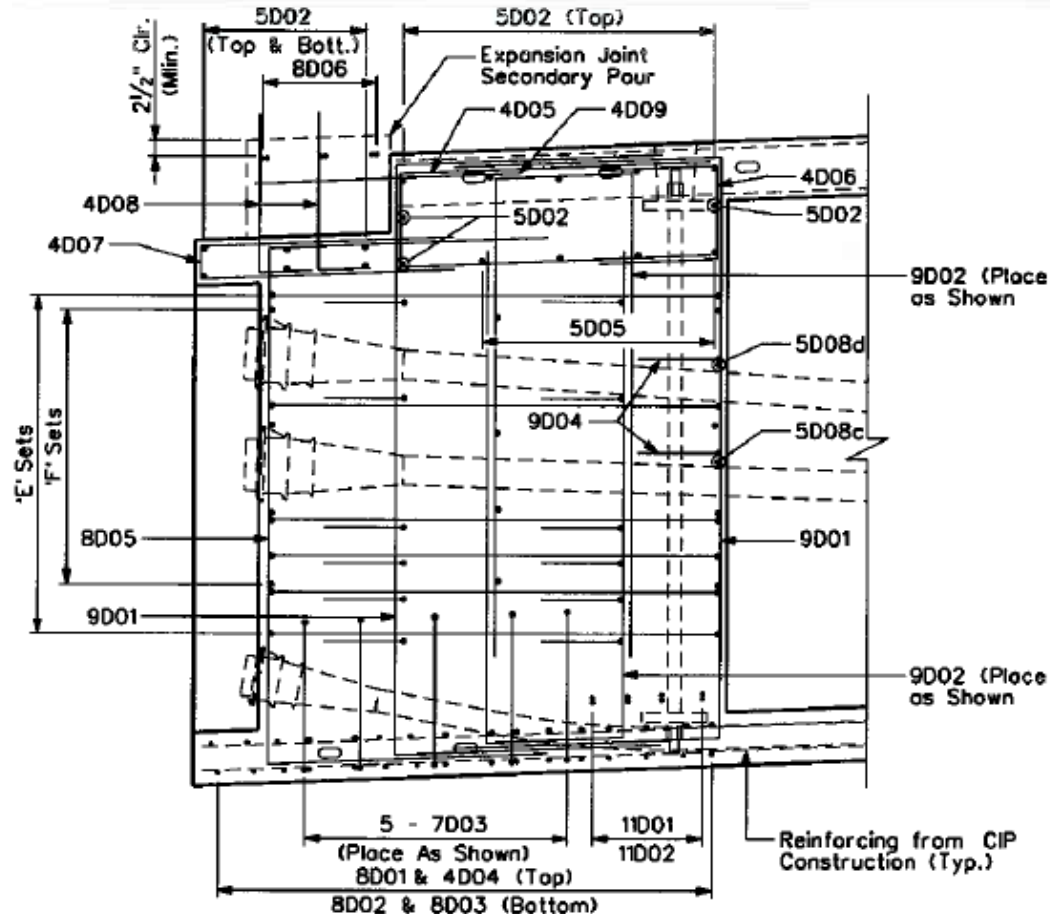

SECTION E-E

# Use of FEA to develop STM

## Post-tensioning Anchorage Zone

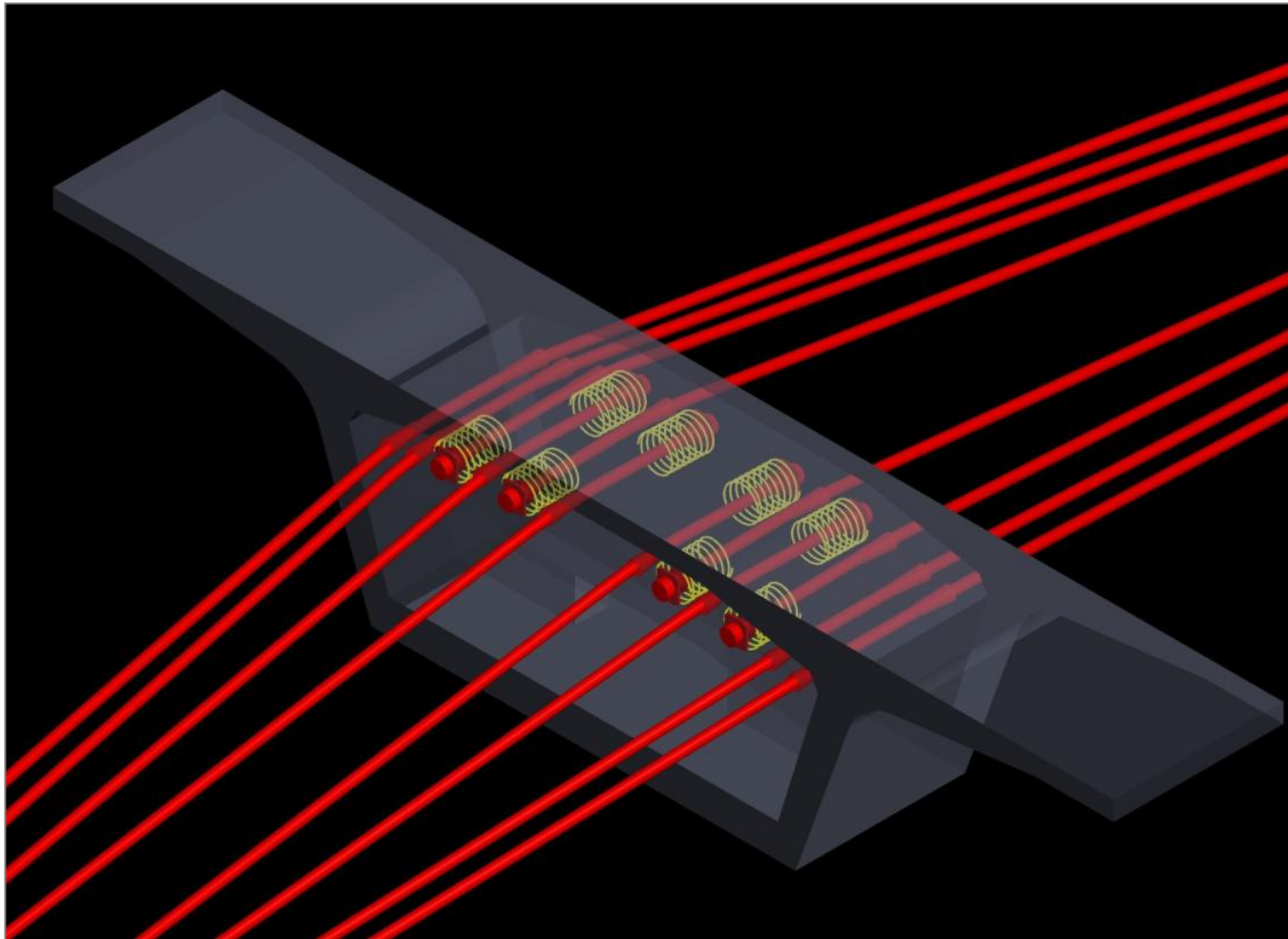

# Use of FEA to develop STM

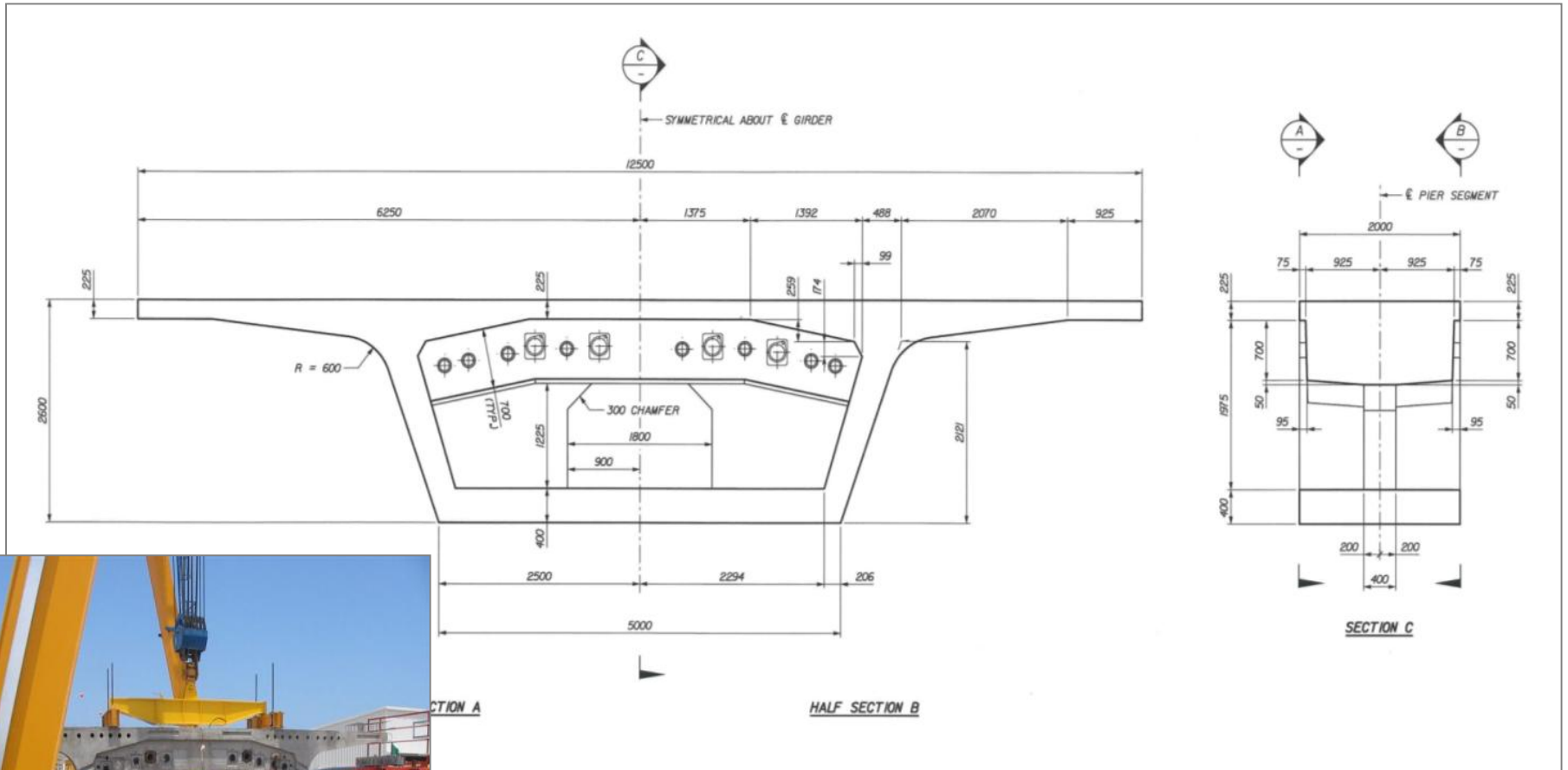

# Use of FEA to develop STM

## Post-tensioning

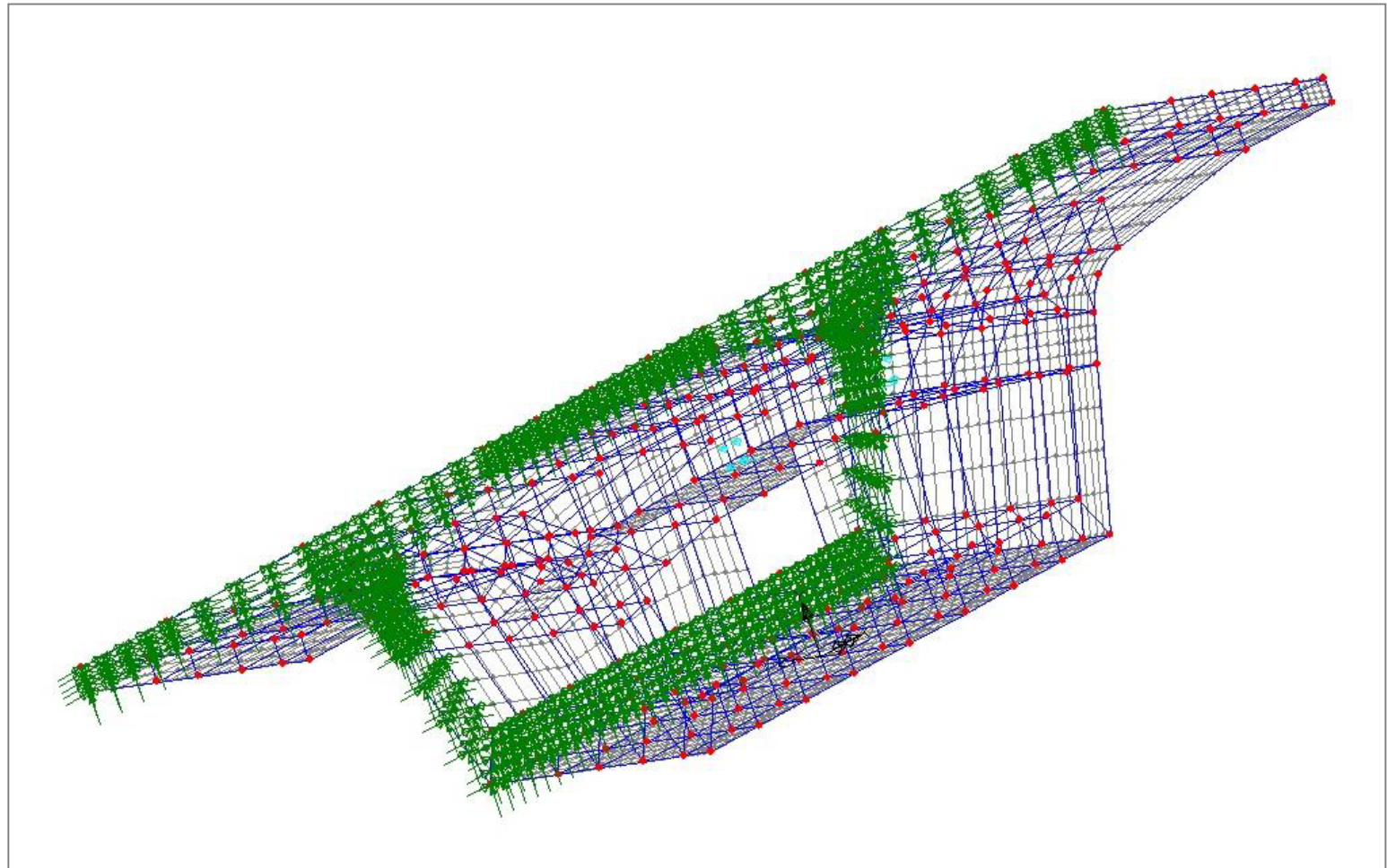

# Use of FEA to develop STM

## Post-tensioning

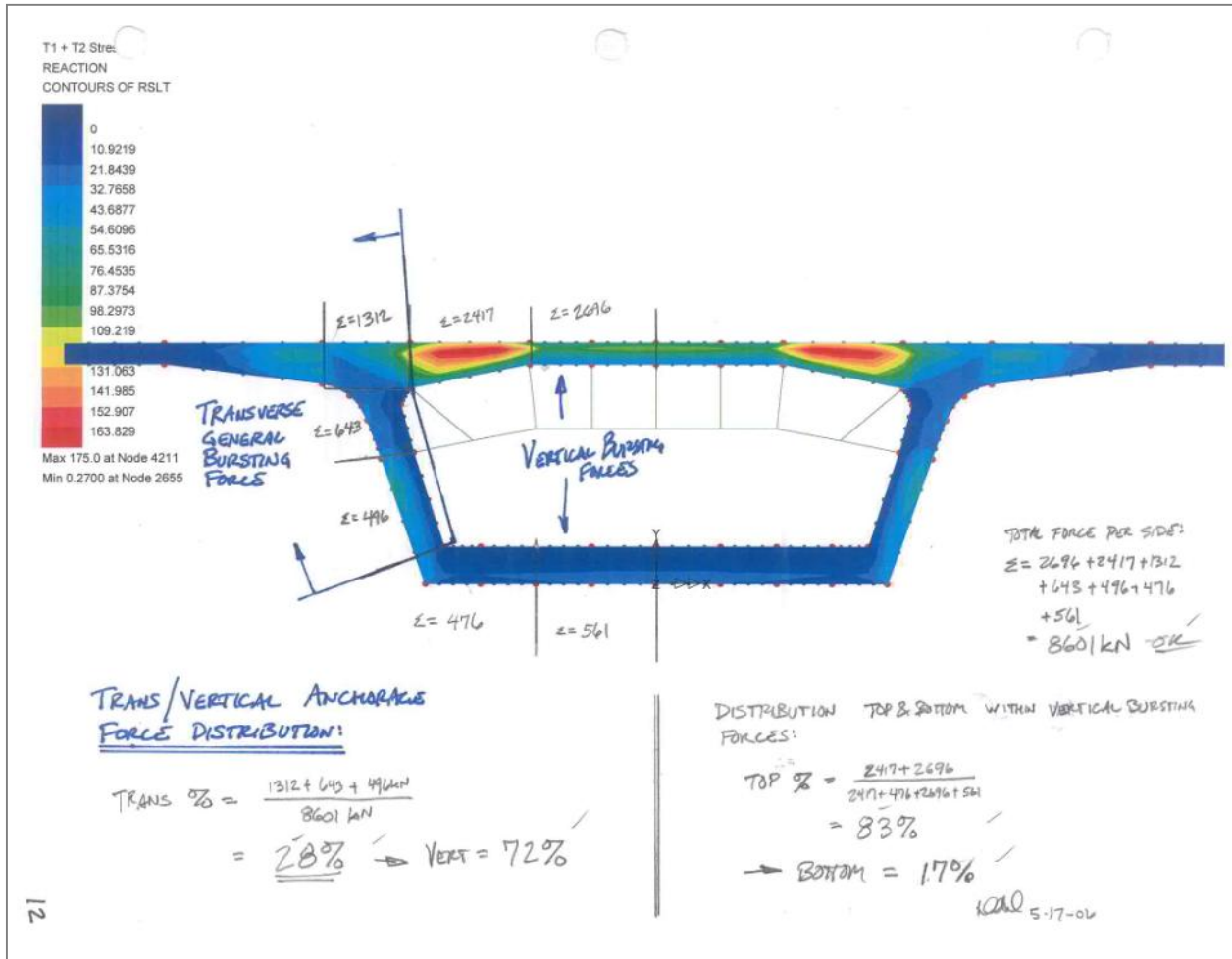

# Use of FEA to develop STM

## Post-tensioning

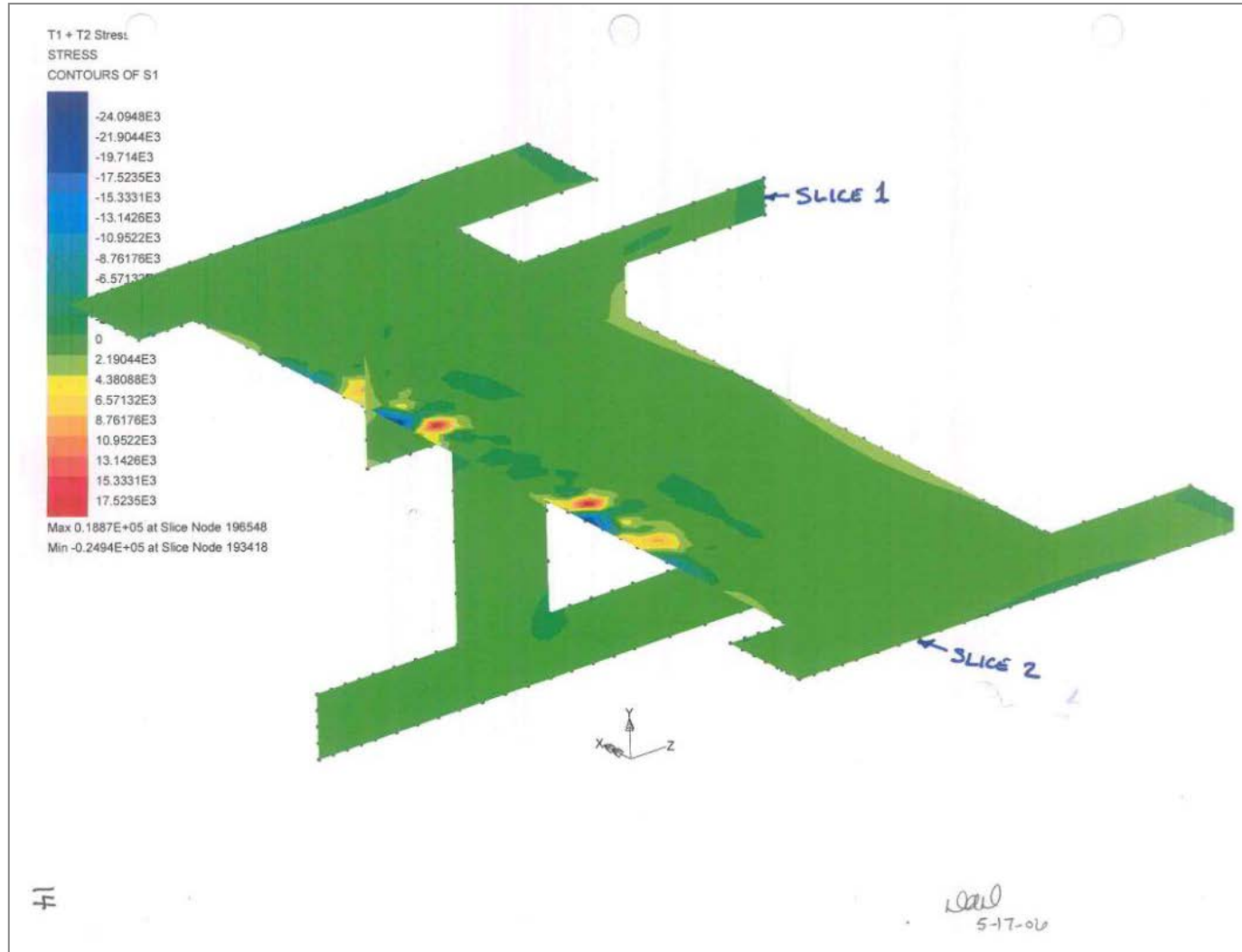

# Use of FEA to develop STM

## Post-tensioning

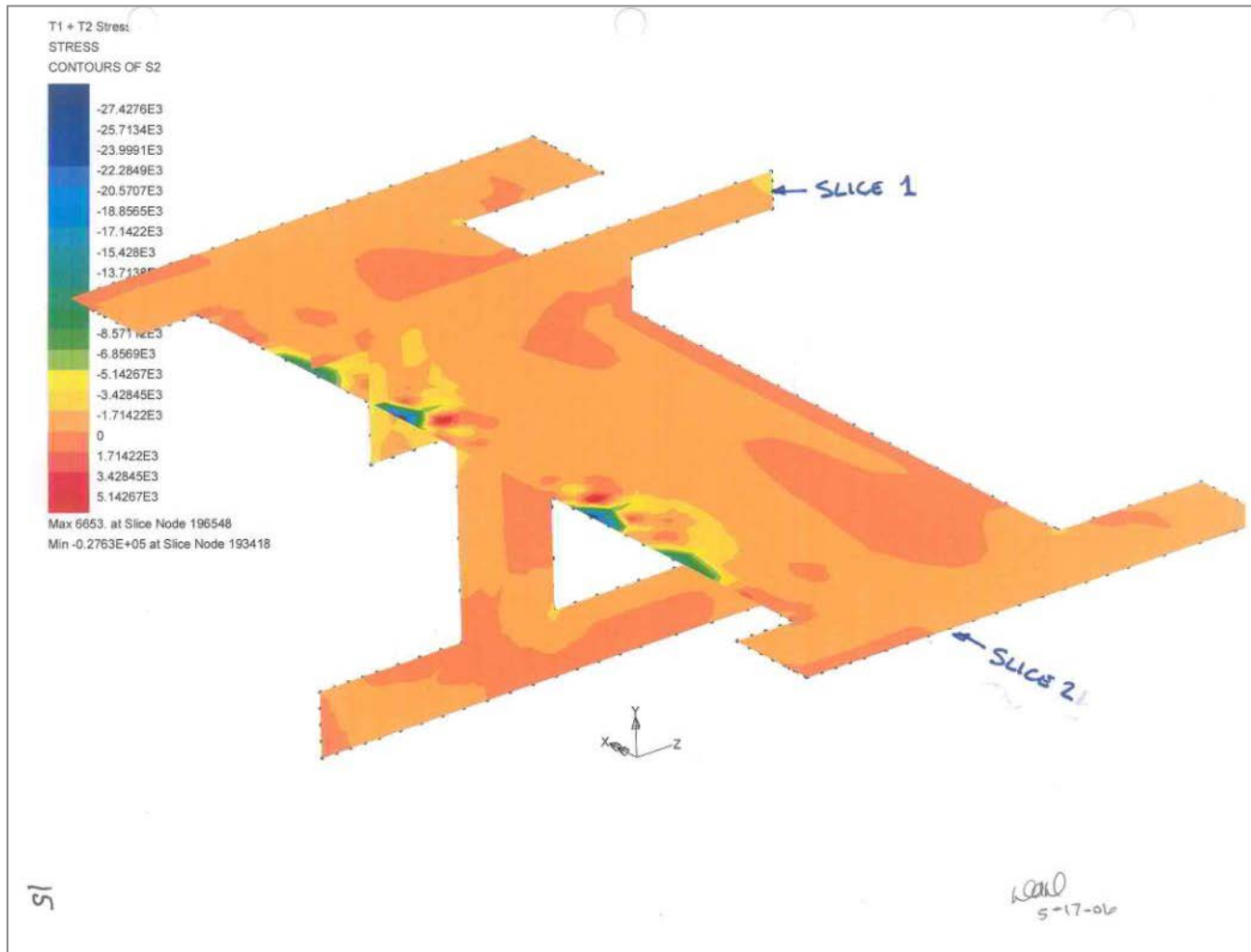

# Use of FEA to develop STM

## Post-tensioning

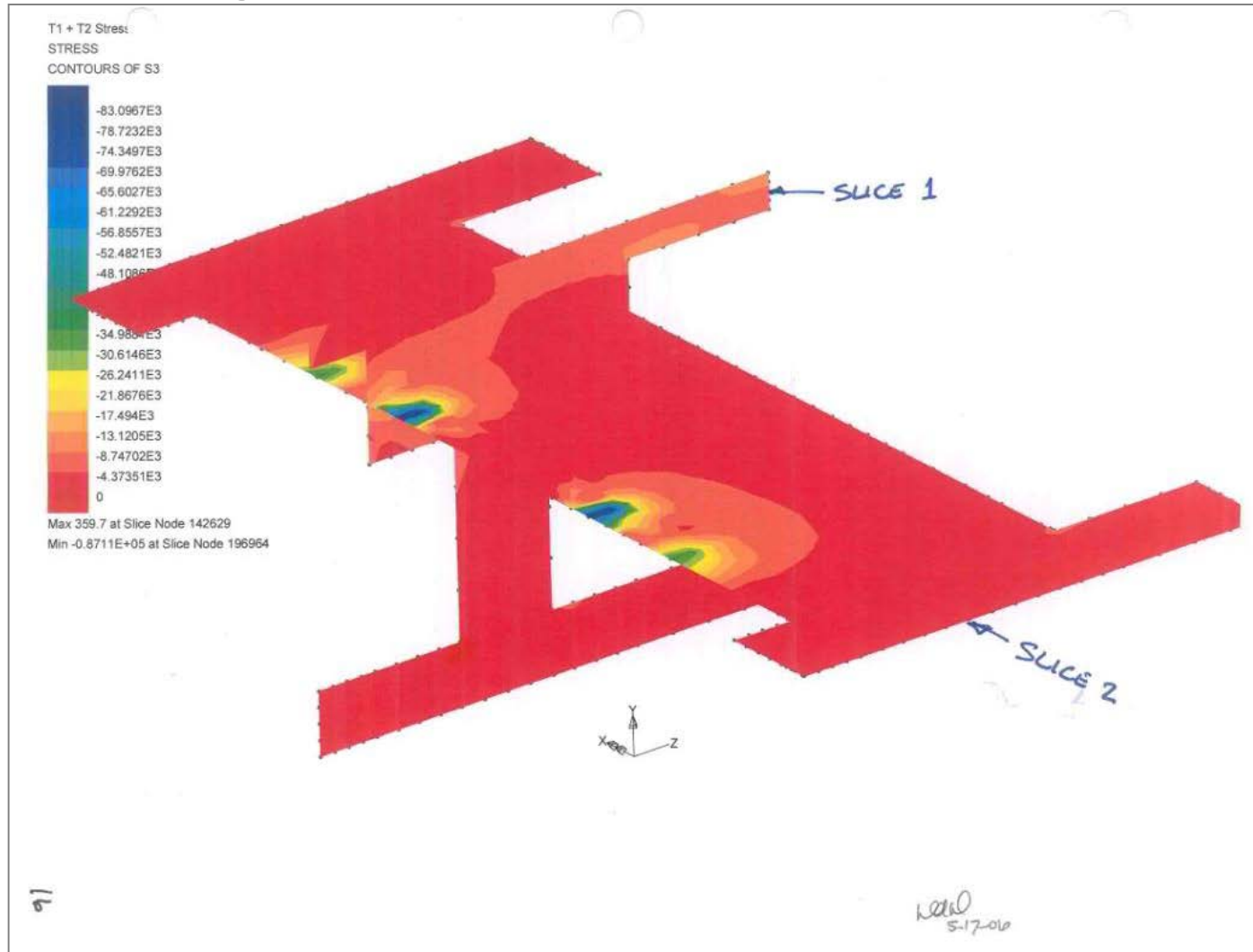



# Use of FEA to develop STM

## Post-tensioning

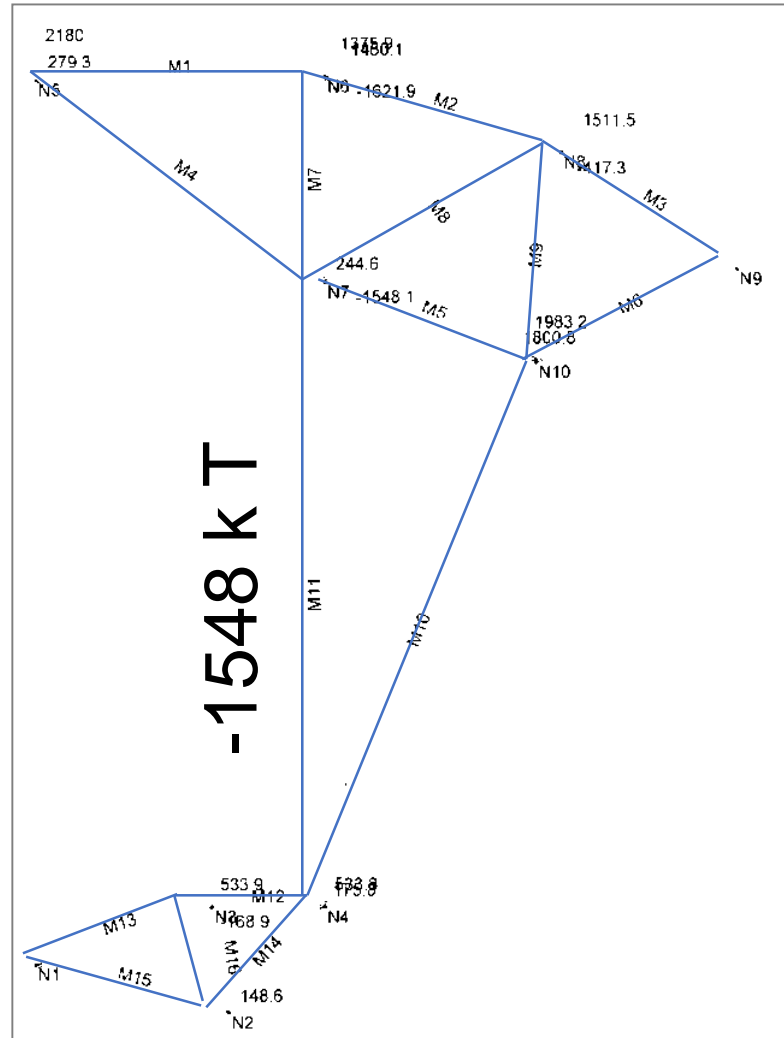

# Use of FEA to develop STM

## Post-tensioning

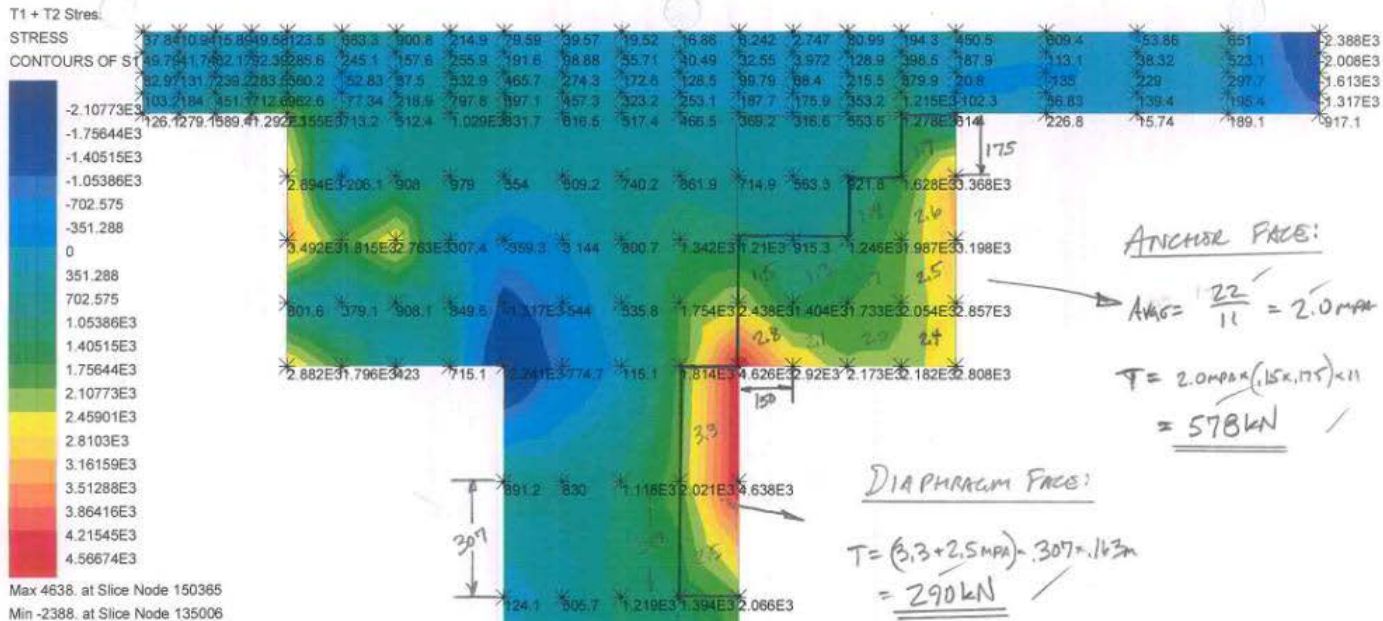

EXIT FACE TRANSVERSE TENSION  
BY INTEGRATION  
 head  
 5-17-06

# Use of FEA to develop STM

## Post-tensioning

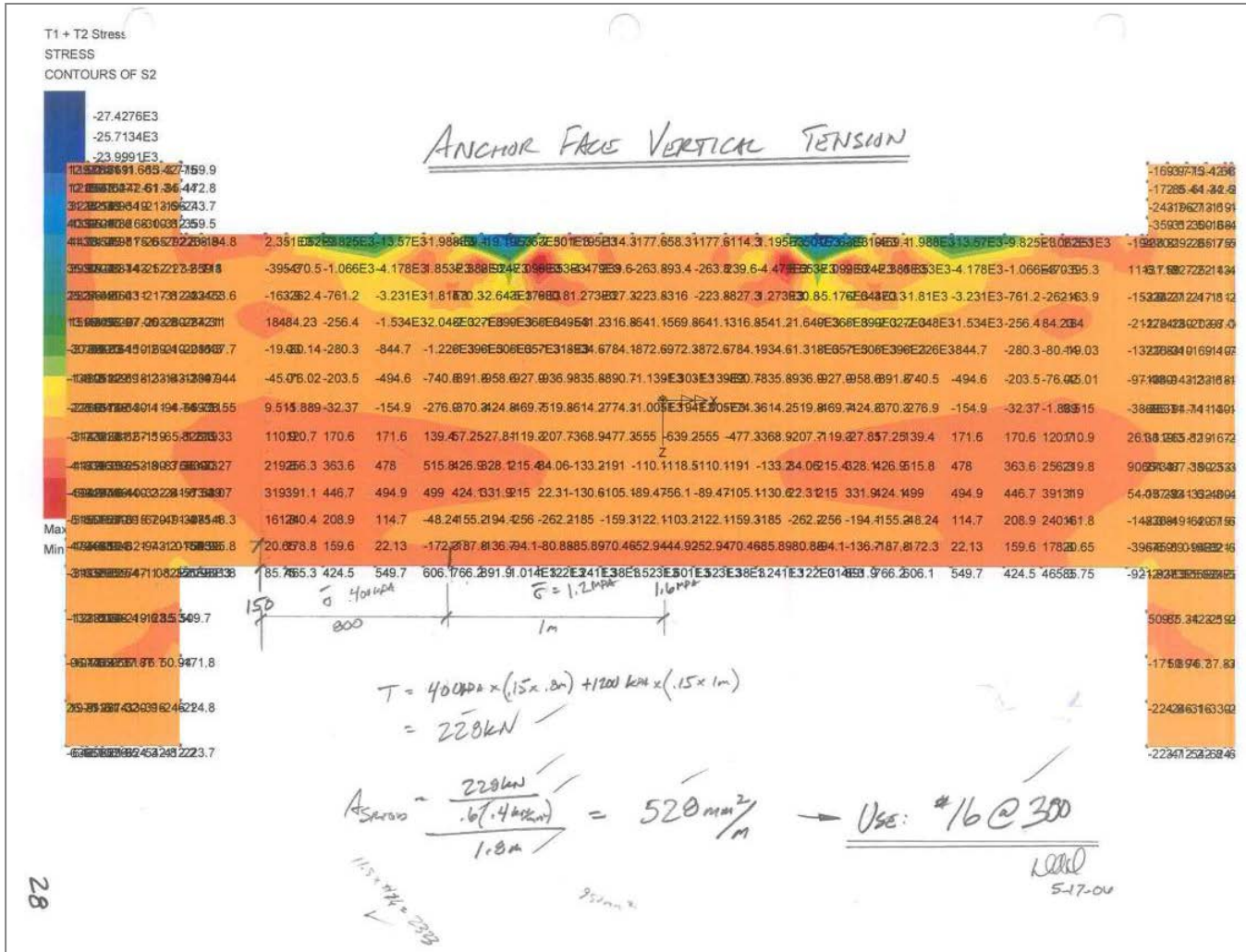

# Case Study: Woodrow Wilson Bridge



# Case Study: Woodrow Wilson Bridge

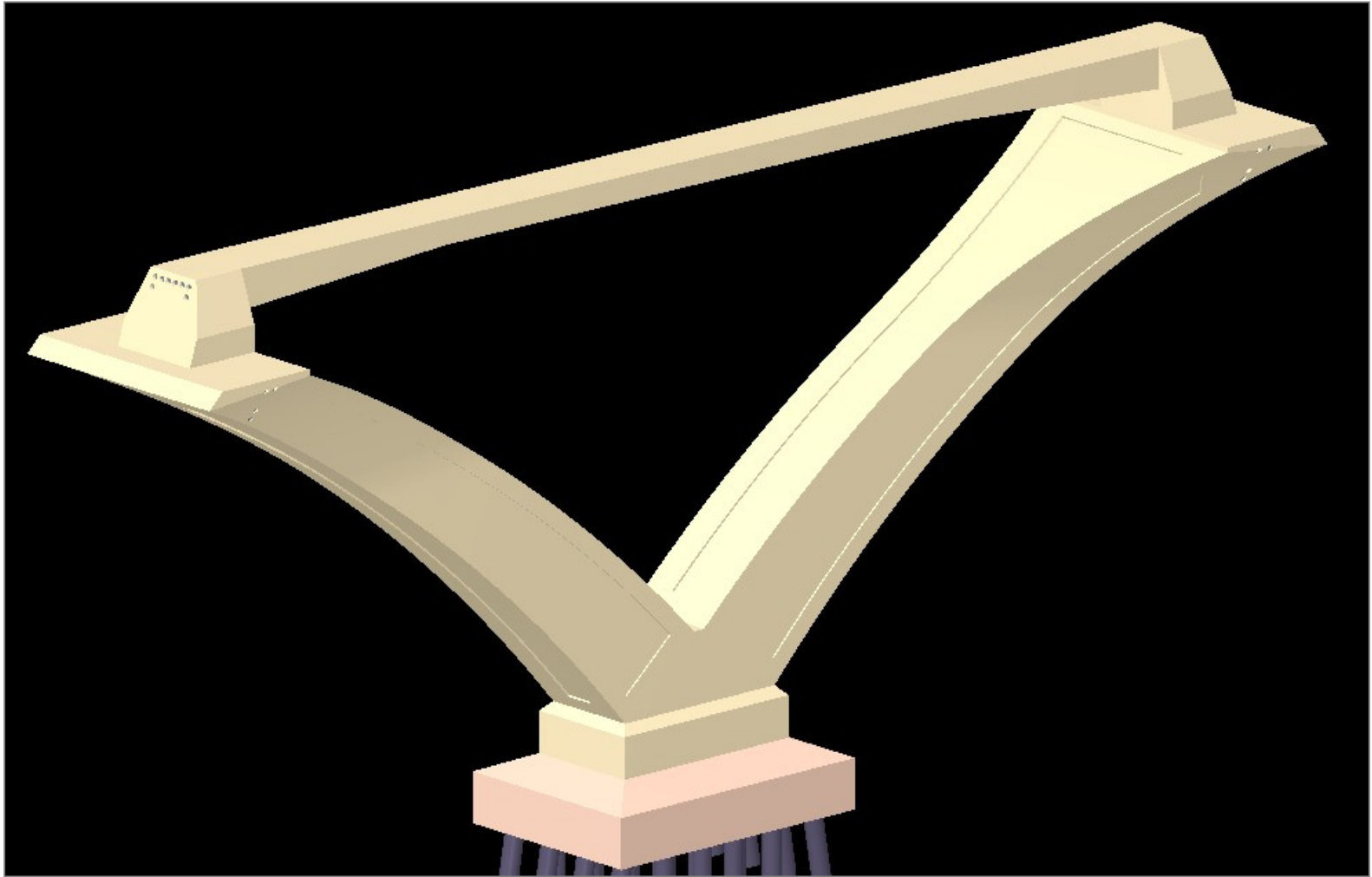

# Case Study: Woodrow Wilson Bridge

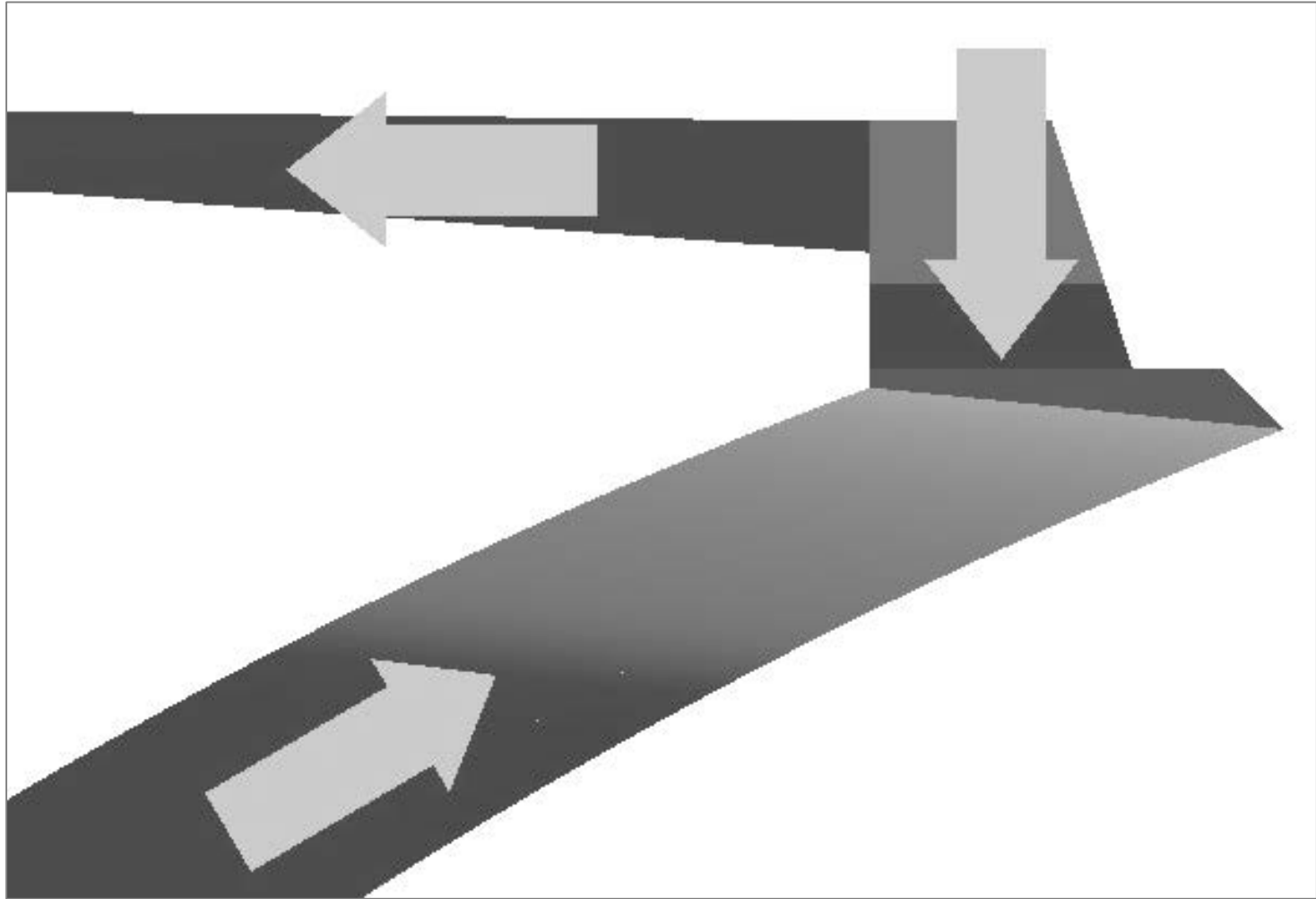

# Case Study: Woodrow Wilson Bridge



# Case Study: Woodrow Wilson Bridge



# Case Study: Woodrow Wilson Bridge

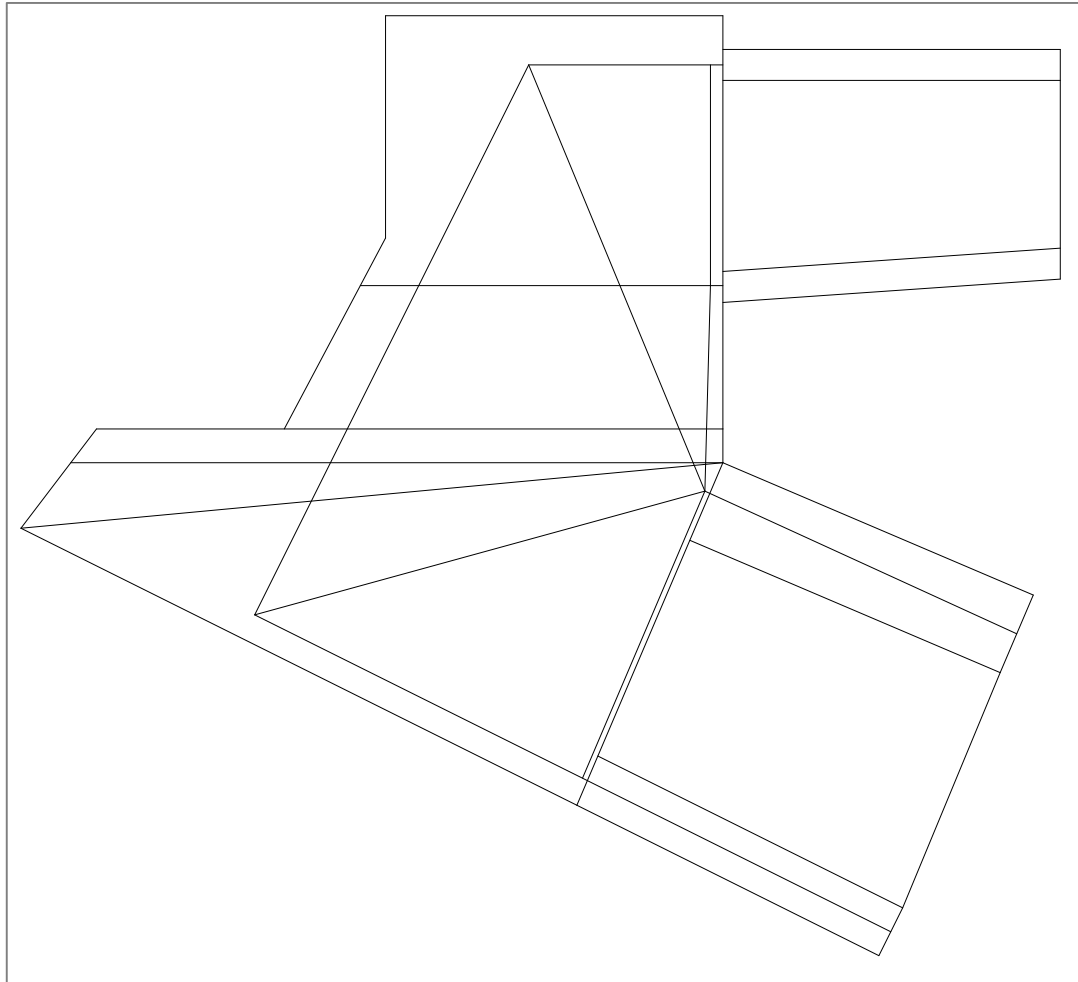

# Case Study: Woodrow Wilson Bridge

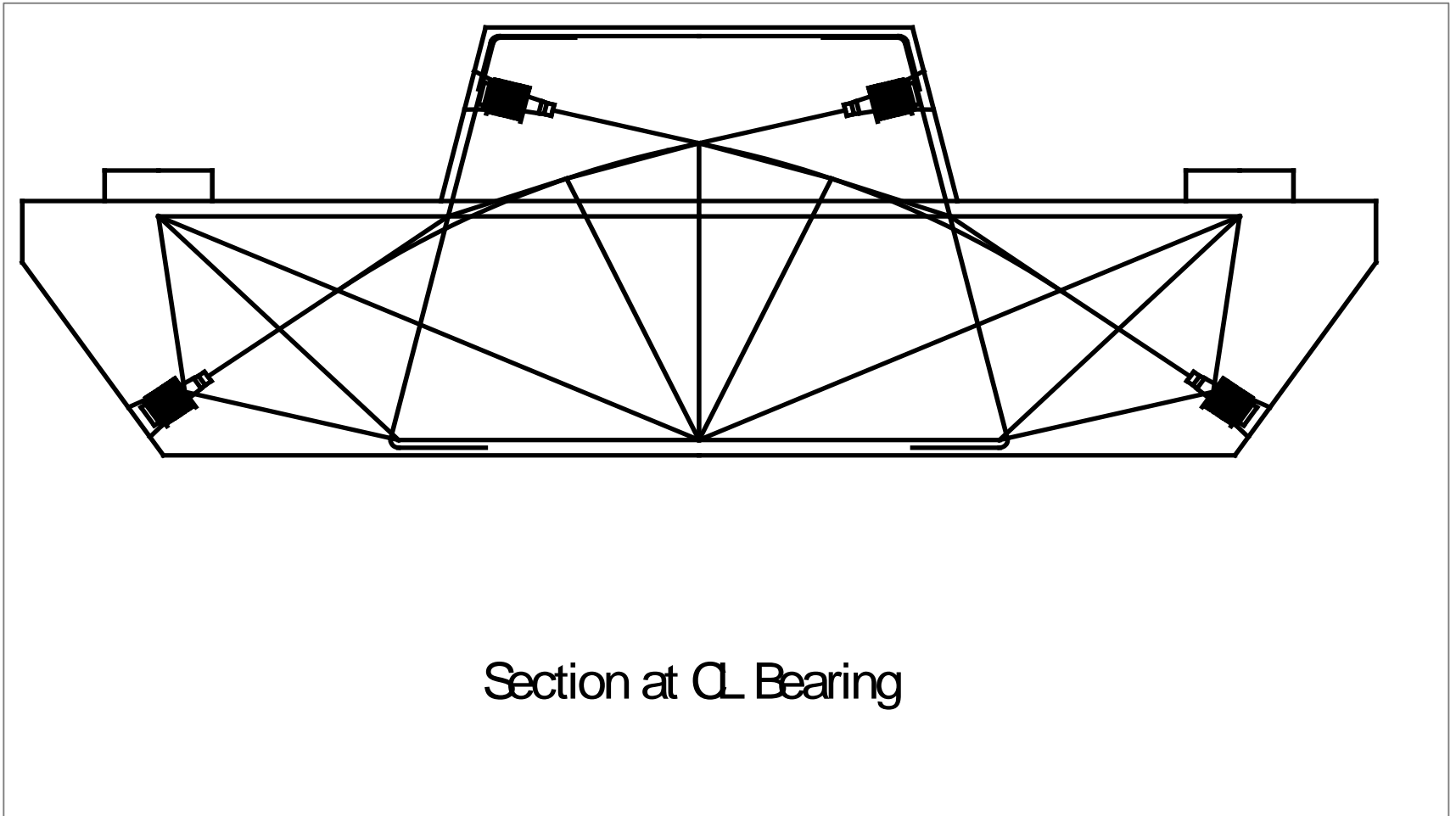

# Case Study: Woodrow Wilson Bridge

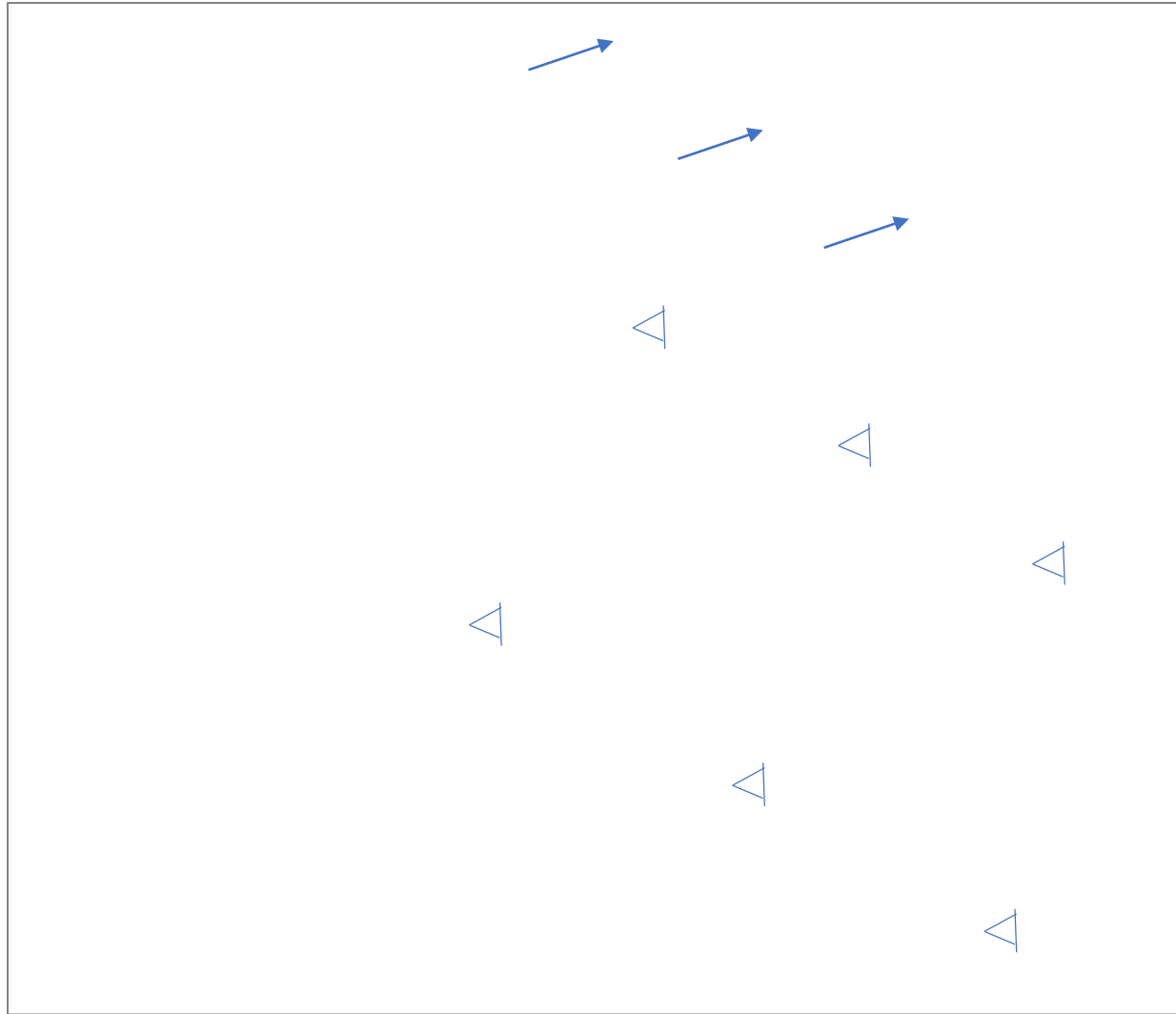

# Case Study: Woodrow Wilson Bridge

